



neptronic[®]

Gas Fired Humidifier

SKG4-E Series

Installation Instructions and User Manual



READ AND SAVE THESE INSTRUCTIONS





Safety

What To Do If You Smell Gas!



Do not try to light any appliance.

Do not touch any electrical switch; do not use any telephone in your building.

Immediately call your gas supplier from an off-site telephone.

Follow the gas supplier's instructions.

If you cannot reach your gas supplier, call the fire brigade.

Gas

Before installation, check that the local distribution conditions, nature of gas and pressure, and the current state adjustment of the appliance are compatible.

Improper installation, adjustment, alteration, service, maintenance or use can cause carbon monoxide poisoning, explosion, fire, electrical shock or other conditions which may cause personal injury or property damage.



This appliance **MUST** be used only in sufficiently ventilated space. Consult instructions before installation and use of this appliance.

Installation and service **MUST** be performed by a qualified gas installer, service agency, or the gas supplier.

Ensure that local regulations concerning the provision of gas installations are followed.

Electricity



All work concerned with electrical installation **MUST** only be performed by skilled and qualified technical personnel, such as an electrician or a technician with appropriate training. The customer is always responsible for ensuring the suitability of the technical personnel.

Ensure that the local regulations concerning the provision of electrical installations are followed.

Health and Safety

Neptronic has considered the aspects of the design of their humidification systems to reduce as much as possible the risk of Legionnaires' disease and other similar conditions, but it is important that users are also aware of their responsibilities under Health and Safety regulations in reducing the risk of legionellosis.

To prevent the growth of Legionella, users are required to:

- Avoid water temperature that favours the growth of Legionella (20-45°C).
- Avoid water stagnation.
- Clean and disinfect the humidification system in accordance with Health and Safety regulations and enclosed instructions.
- Have a competent person carry out a risk assessment of the water system supplying the humidifier, to ensure that the water supply is of an acceptable quality.

Correct Use

Neptronic systems and products are designed only for humidification use.

Any other application is not considered as usage for the intended purpose. The manufacturer cannot be made liable for any damage resulting from incorrect use.



Access

The SKG4 cabinet keys **MUST** never be left in the door locks, as this may cause unauthorized access to live electrical parts. Always store keys centrally with a nominated responsible person.

Water

Neptronic systems are designed to be used with tap, reverse osmosis or deionized water. On no account must any other fluids or chemicals be introduced into the system without first consulting Neptronic or its authorized distributor.

Water supply must not exceed the max pressure of 4.8 bar or pressure limits laid out in the specification and installation must comply with local regulations. Your attention is drawn to your responsibilities as outlined in the Health and Safety regulations. The control of Legionella bacteria in water systems and your SKG4 humidifier must be included in the risk assessment of the water system in your building as a whole. In particular, if the humidifier is turned off for prolonged periods, you must ensure that the unit is drained and that stagnation is avoided in pipe work supplying it.

A competent individual or organization must be appointed to carry out water tests. A wide range of different tests are available to identify the presence of microbes in water, including total viable count (TVC), temperature-range specific tests and identification of particular species types including Legionella. It is the responsibility of the person on whom the statutory responsibility falls to determine the type and frequency of this and all other controls and preventative measures outlined in this manual.

Foreword

Neptronic Company Overview

Founded in 1976, we're a private corporation that designs, manufactures and distributes products for the HVAC industry. Our product line includes intelligent controllers, electronic actuators, actuated valves, humidifiers and electric heaters.

Our products are designed and manufactured by over 250 dedicated employees in our 7,500 m² (80,000 ft²) state-of-the-art facility located in Montreal, Canada. Using a vertical integration model, our entire manufacturing chain is under one roof, from software and hardware development, to SMT circuit board assembly, to sheet metal fabrication, to product testing, ensuring that our products are engineered to last.

We currently hold several national and international patents and with our continued commitment to research and development, we provide innovative products and technologies for the ever-evolving challenges of the HVAC industry. Exporting over 70% of our sales, we have an exclusive distribution network around the globe that provides comprehensive solutions to our worldwide customers.

About the Manual

These installation and operation instructions have been developed to facilitate the installation of the SKG4 humidifier.

- The strict application of these instructions will ensure the conformity of your installation and operation as per the manufacturer's recommendations.
- The application of these instructions is one of the conditions for the application of the warranty.
- The application of these instructions does not ensure, at any time conformity to procedures, regulation or local codes, regarding electric installation and connection to local water supply.

This product has been declared to conform to applicable European safety and electromagnetic compatibility standards and directives and bear the CE mark. The certificate of conformity CE is available upon request to the manufacturer.

2026[®]: All rights reserved. This document cannot be reproduced totally or partially by any means whether, electronic, mechanical, photocopy, recording or other, without prior written authorization of Neptronic.

Correct Use

Neptronic systems and its products are designed only for humidification use. Any other application is not considered appropriate for the intended purpose. The manufacturer cannot be made liable for any damage resulting from incorrect use.

General Warranty

This product is subject to the terms and conditions described at <http://www.neptronic.com/Sales-Conditions.aspx>.

Contents

Overview	6
Handling and Lifting	6
List of Accessories Supplied	7
Other Related Documents	7
Technical Specifications	7
Visual Overview	8
Standard Humidifier Unit	8
Position and Dimension of Connections	9
Option - Ducted Combustion Air Inlet Dimensions	10
Weather Proof Enclosure	11
Multiple Module Composition	12
Installation Overview	14
Installation Method Statement	14
Installation Steps	14
Stage 1 - Unit Positioning and Mounting	15
General Recommendations	15
Ambient Condition and Altitude	16
Minimum Clearances	16
Minimum Clearances - Weather Proof Enclosure	17
Weather Proof Enclosure Installation on Floor/Roof	18
Weather Proof Enclosure Installation on Roof Curb	18
Stage 2 - Steam Distribution Installation	19
Fundamental Design Concepts	19
Weather Proof Enclosure Steam Outlets	20
Steam Outlet Dimension and Quantity - Weather Proof Enclosure	20
Steam Dispersion General Recommendations	21
Selection of Steam Distribution Manifolds	21
S.A.M.E2 System	21
Positioning the S.A.M.E2	21
Multi-Steam System	24
Selection of Multi-Steam System	24
Steam Pipe Work to Duct Connections with Multi-Steam	25
Stage 3 - Gas Supply Connection	27
Gas Pipe Diameter	28
Gas Leak Test	28
Stage 4 - Water Supply Installation	29
Water Inlet Specifications	29
Chloride Concentration in Water Supply	29
Water Treatment Guidelines	29
Supply Line Installation	30
Stage 5 - Water Drain Connection	31
Water Drain Specifications	31
Water Drain Installation	31

Pan Drain Connection on Weather Proof Enclosure	32
Weather Proof Enclosure Water Drain Valve	33
Stage 6 - Combustion Air Installation	34
Combustion Air Specification - Natural Ventilation	34
Natural Ventilation Installation	35
Ducted Combustion Air	35
Stage 7 - Flue Gas Venting Connection	39
Flue Gas Venting Specification	39
Flue Gas Terminal	40
Minimum Spacing	40
Stage 8 - Electrical Supply and Installation	42
Electrical Power Supply	42
Stage 9 - Electrical Control Connections	43
Electrical Control Connections	43
Network Communication (TB1 and TB2)	43
Safety Contact Connections (TB3)	43
Control Analog Connections (TB4)	44
Dry Contacts (TB5 and TB6)	44
Humidifier Control	45
Analog Signals	45
Humidity Control by Humidistat (External Mode)	45
Humidity Control by Humidifier (Internal Mode)	46
Humidity Control by External Signal	47
Network Communication	48
Controls Placement (Steam Dispersed into a Duct or AHU)	49
Controller Configuration	50
Control Panel Features	50
Idle Screen	51
Menu Access	51
Menu Navigation and Configuration	52
Menu - General	53
Menu - User Settings	55
Menu - Service	56
Menu - Installation	57
Menu - Integration	61
List of Alarms	64
Manual Water Level Calibration	66
Start-up Procedure	68
Service	70
Cleaning the Humidifier	70
Inspecting the Humidifier Components	72
Troubleshooting	75
Exploded View and Bill of Material	77



Overview

Handling and Lifting



Lifting or handling **MUST** be carried out by trained and qualified personnel. Ensure that the lifting operation has been properly planned, assessed for risk and that the equipment has been checked by a competent Health and Safety representative, and effective control measures are in place.

It is the customer's responsibility to ensure that the operators are trained in handling heavy goods and to enforce the relevant lifting regulations.

Any personnel handling or lifting the SKG4 humidifier must follow the Lifting Operations and Lifting Equipment Regulations 1998 and Approved Code of Practice L113. The regulation imposes duties on employers, self-employed persons and persons who have control, to any extent of lifting equipment.

The SKG4 humidifier **MUST** be handled and lifted with care at all times and remain in its original packaging for as long as possible, prior to installation.

The SKG4 humidifier package may be carried using a forklift from the underside. Exercise caution before lifting to ensure that the load is balanced.

The optional weather proof enclosure is provided with four (4) lifting eyelets located at each corner on top of the enclosure.

Refer to the Dimensions and Weight table in the Standard Humidifier Unit section for system dry weights.

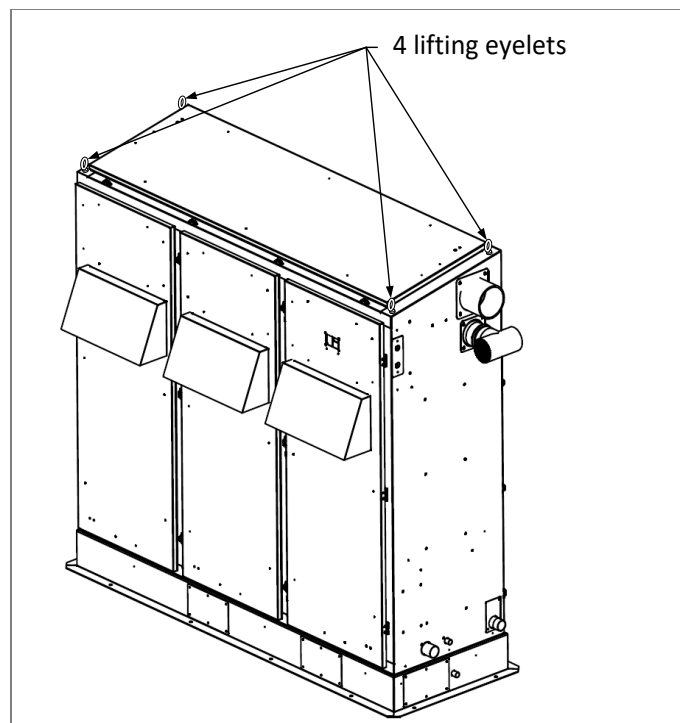

Illustration 1 - Lifting (Weather Proof Enclosure)

Unpacking

The SKG4 humidifier is shipped in a wooden crate. Ensure packing wooden crate and skid is removed prior to commissioning.



List of Accessories Supplied

The following accessories are supplied with the SKG4 humidifier:

- 2 sets of keys.
- 2 adjustable steam hose collars per module to connect on the steam output (standard enclosure).
- 2 adjustable steam hose collars per internal steam manifold (weather proof enclosure option).
- 1 Installation Instructions and User Manual.

Other Related Documents

- Wiring Diagram
- Combustion Field Adjustment Instructions
- BACnet Communication Module User Guide (for humidifiers with BACnet option)
- Modbus Communication Module User Guide (for humidifiers with Modbus option)

Technical Specifications

Table 1 - Technical Specifications

Model	No. of Modules	Steam Capacity (kg/hr)	Input Capacity (kW)	Current at 230V (A)	No. of Outlets	Multi-Steam Header Diameter (mm)
SKG4-E0501 N/P	1	50	49	3.0	1	76
SKG4-E0701 N/P	1	70	63	3.0	1	76
SKG4-E0801 N/P	1	80	70	3.0	1	76
SKG4-E1001 N/P	1	100	73	3.0	1	76
SKG4-E1202 N/P	2	120	112	4.5	2	100
SKG4-E1502 N/P	2	150	126	4.5	2	100
SKG4-E1702 N/P	2	170	136	4.5	2	100
SKG4-E2002 N/P	2	200	146	4.5	2	100
SKG4-E2503 N/P	3	250	206	6.0	3	125
SKG4-E2703 N/P	3	270	209	6.0	3	125
SKG4-E3003 N/P	3	300	219	6.0	3	125
SKG4-E3504 N/P	4	350	279	7.5	4	(2x) 100
SKG4-E3704 N/P	4	370	282	7.5	4	(2x) 100
SKG4-E4004 N/P	4	400	292	7.5	4	(2x) 100

Note 1: Maximum static duct pressure is 1.25 kPa (12.5 mbar). For higher static duct pressures, consult Neptronic or its authorized distributor.

Note 2: Standard humidifier is designed for natural ventilation combustion air. "Ducted Combustion Air" option is available upon request. See Stage 6 of installation procedure for more details.

Note 3: See the Electrical Power Supply section on page 42 for current ratings for models with the weather proof enclosure.





Visual Overview

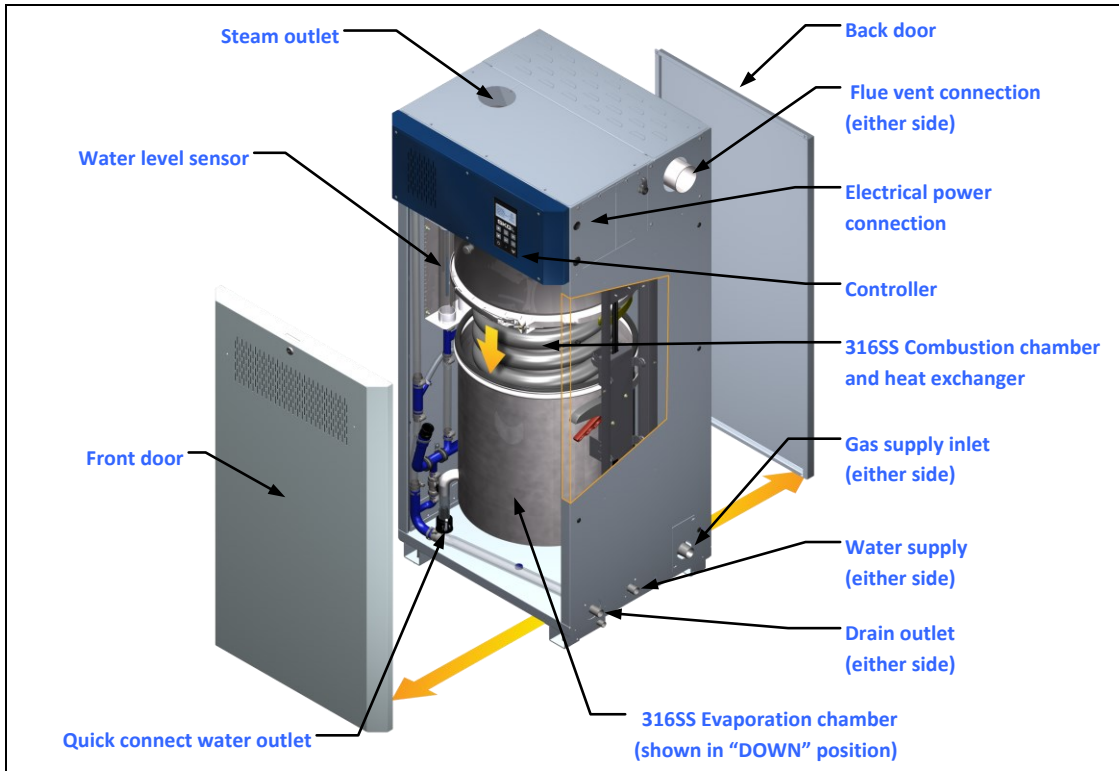

Illustration 2 - Humidifier Overview

Standard Humidifier Unit

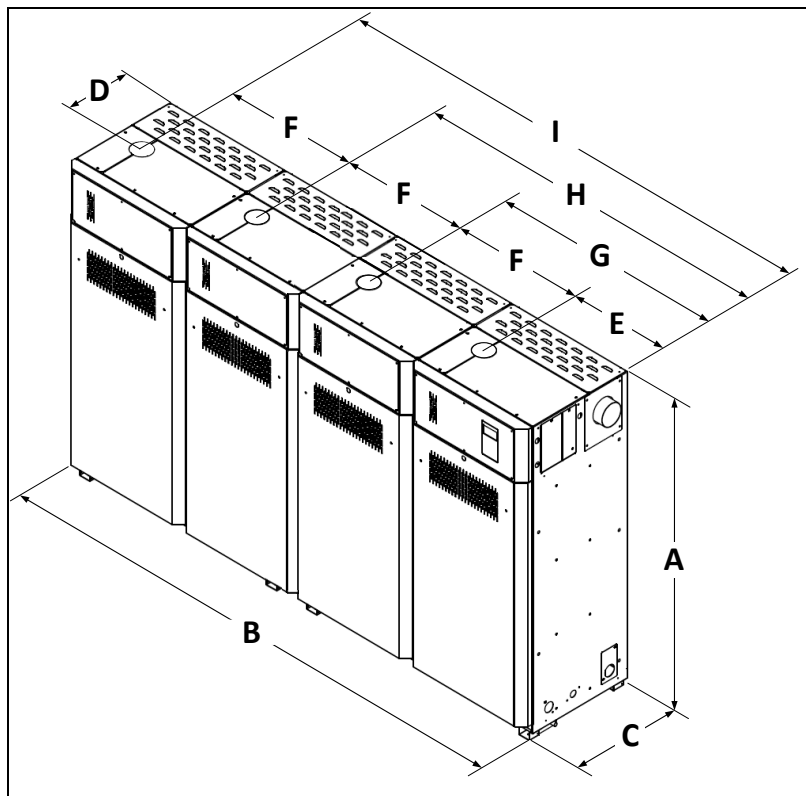

Illustration 3 - Standard Humidifier



Table 2 - Dimensions and Weight (Standard Humidifier)

Model	No. of Modules	Steam Outlet		Dimensions (mm)									Weight (kg)	
		Qty	Dia. (mm)	A	B	C	D	E	F	G	H	I	Empty	Full of Water
SKG4-E0501 N/P SKG4-E0701 N/P SKG4-E0801 N/P SKG4-E1001 N/P	1	1	Ø76	1372	610	560	280	470	-	-	-	-	145	200
SKG4-E1202 N/P SKG4-E1502 N/P SKG4-E1702 N/P SKG4-E2002 N/P	2	2	Ø76	1372	1220	560	280	470	610	1080	-	-	274	384
SKG4-E2503 N/P SKG4-E2703 N/P SKG4-E3003 N/P	3	3	Ø76	1372	1830	560	280	470	610	1080	1690	-	431	600
SKG4-E3504 N/P SKG4-E3704 N/P SKG4-E4004 N/P	4	4	Ø76	1372	2440	560	280	470	610	1080	1690	2300	576	800

Position and Dimension of Connections

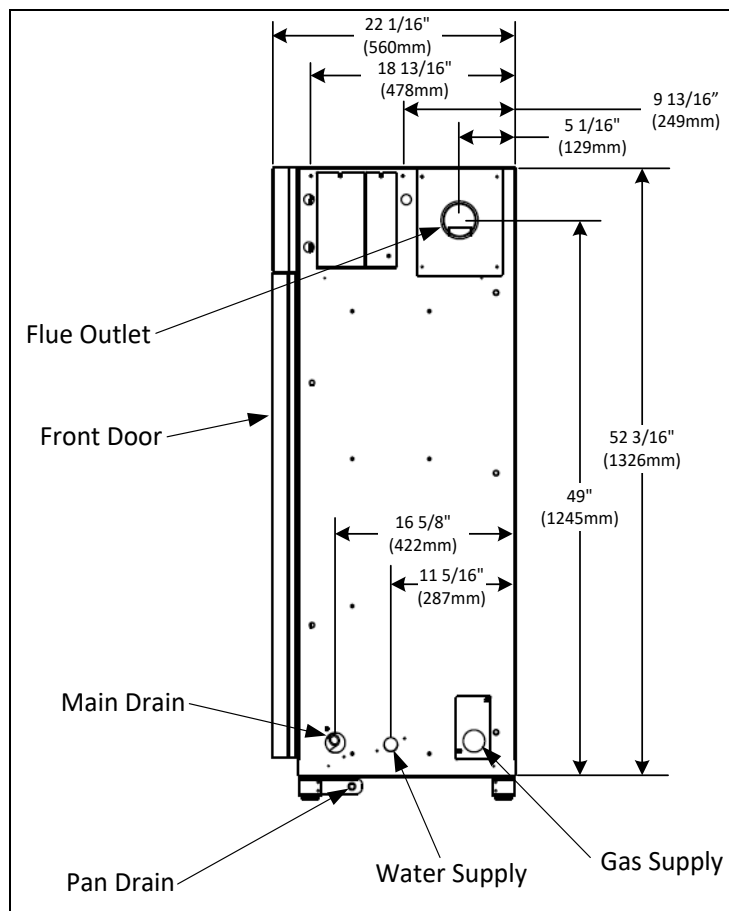

Illustration 4 - Position of Connections



Table 3 - Dimensions of Connections (Standard Humidifier)

Model	No. of Modules	Dimensions (mm)				
		Drain Outlet Diameter	Pan Drain Diameter	Water Inlet Diameter	Gas Inlet Diameter	Flue Outlet Diameter
SKG4-E0501 N/P SKG4-E0701 N/P SKG4-E0801 N/P SKG4-E1001 N/P	1	Ø22	Ø18	Ø15	Ø25	Ø76
SKG4-E1202 N/P SKG4-E1502 N/P SKG4-E1702 N/P SKG4-E2002 N/P	2	Ø36	Ø18	Ø15	Ø25	Ø100
SKG4-E2503 N/P SKG4-E2703 N/P SKG4-E3003 N/P	3	Ø50	Ø18	Ø15	Ø40	Ø125
SKG4-E3504 N/P SKG4-E3704 N/P SKG4-E4004 N/P	4	Ø50	Ø18	Ø15	Ø40	Ø125



Note: Drain outlet, water supply inlet, gas supply inlet and flue outlet are located on the right hand side of the humidifier. Left hand side location of any of these outlets or inlets is available upon request.

Option - Ducted Combustion Air Inlet Dimensions

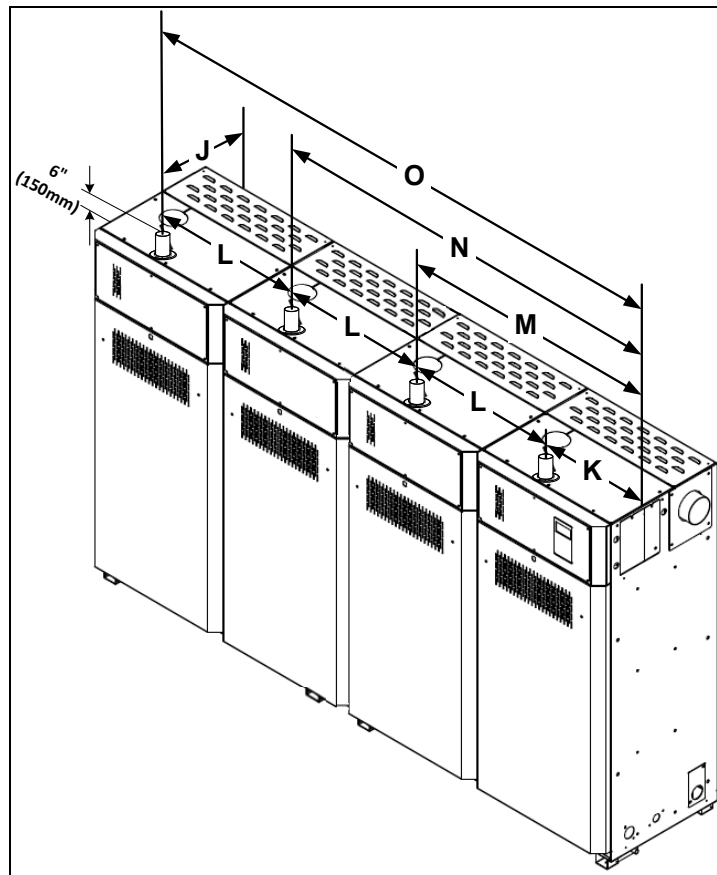

Illustration 5 - Ducted Combustion Air Inlet Dimensions

Table 4 - Dimensions and Weight (Ducted Combustion)

Model	No. of Modules	No. of Air Inlet(s)	Air Inlet Dia. (mm)	Dimensions (mm)					
				J	K	L	M	N	O
SKG4-E0501 N/P SKG4-E0701 N/P SKG4-E0801 N/P SKG4-E1001 N/P	1	1	Ø51	448	352	-	-	-	-
SKG4-E1202 N/P SKG4-E1502 N/P SKG4-E1702 N/P SKG4-E2002 N/P	2	2	Ø51	448	352	609	962	-	-
SKG4-E2503 N/P SKG4-E2703 N/P SKG4-3E003 N/P	3	3	Ø51	448	352	609	962	1571	-
SKG4-E3504 N/P SKG4-E3704 N/P SKG4-E4004 N/P	4	4	Ø51	448	352	609	962	1571	2180

Weather Proof Enclosure

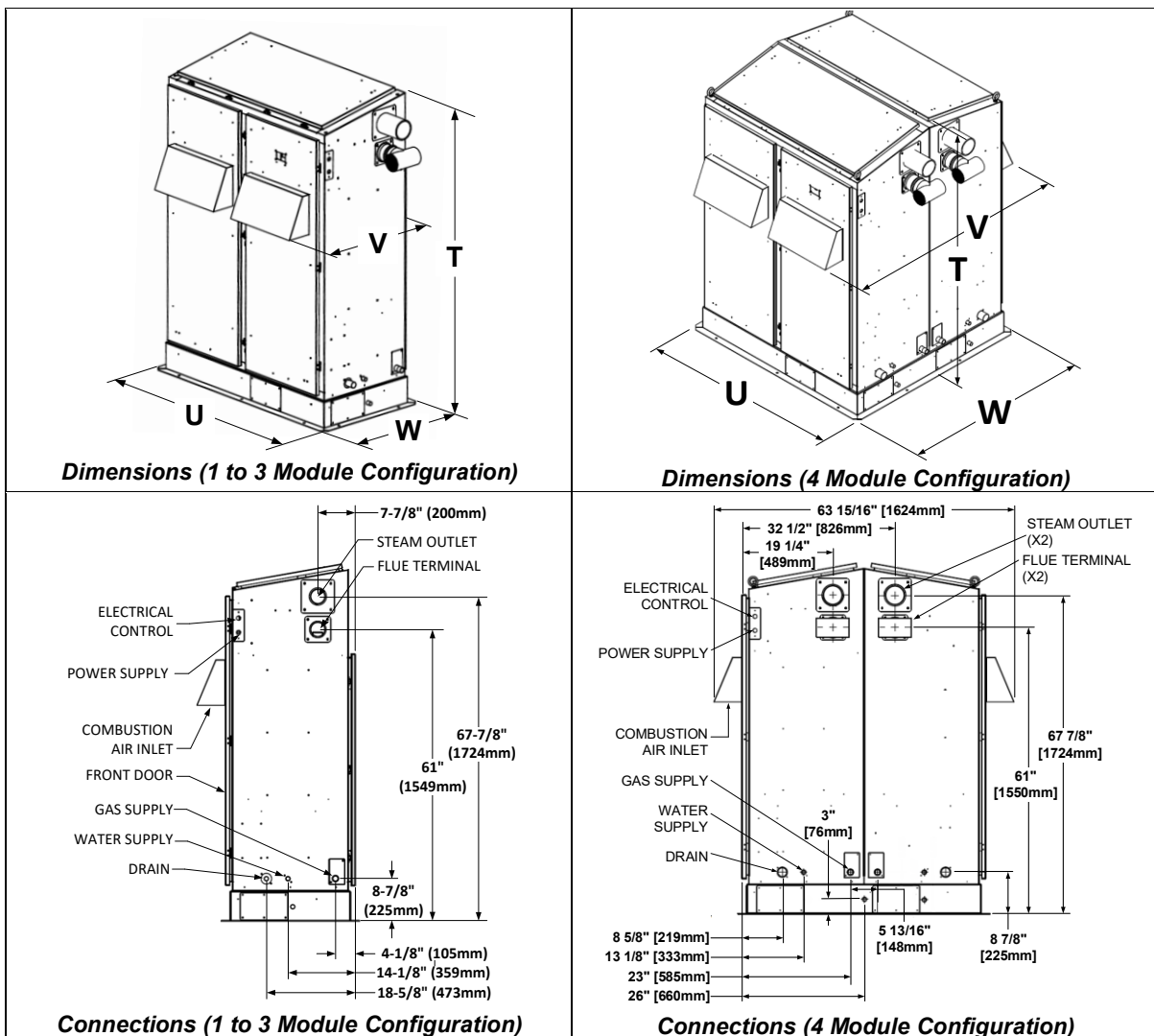

Illustration 6 - Weather Proof Enclosure



Table 5 - Dimensions and Weight (Weather Proof Enclosure)

Model	No. of Modules	Dimensions (mm)				Weight (kg)	
		T	U	V	W	Empty	Full of Water
SKG4-E0501 N/P SKG4-E0701 N/P SKG4-E0801 N/P SKG4-E1001 N/P	1	1898	757	845	714	285	340
SKG4-E1202 N/P SKG4-E1502 N/P SKG4-E1702 N/P SKG4-E2002 N/P	2	1898	1412	845	714	472	582
SKG4-E2503 N/P SKG4-E2703 N/P SKG4-E3003 N/P	3	1898	2070	845	714	653	818
SKG4-E3504 N/P SKG4-E3704 N/P SKG4-E4004 N/P	4	1898	1412	1623	1344	830	1050

Multiple Module Composition

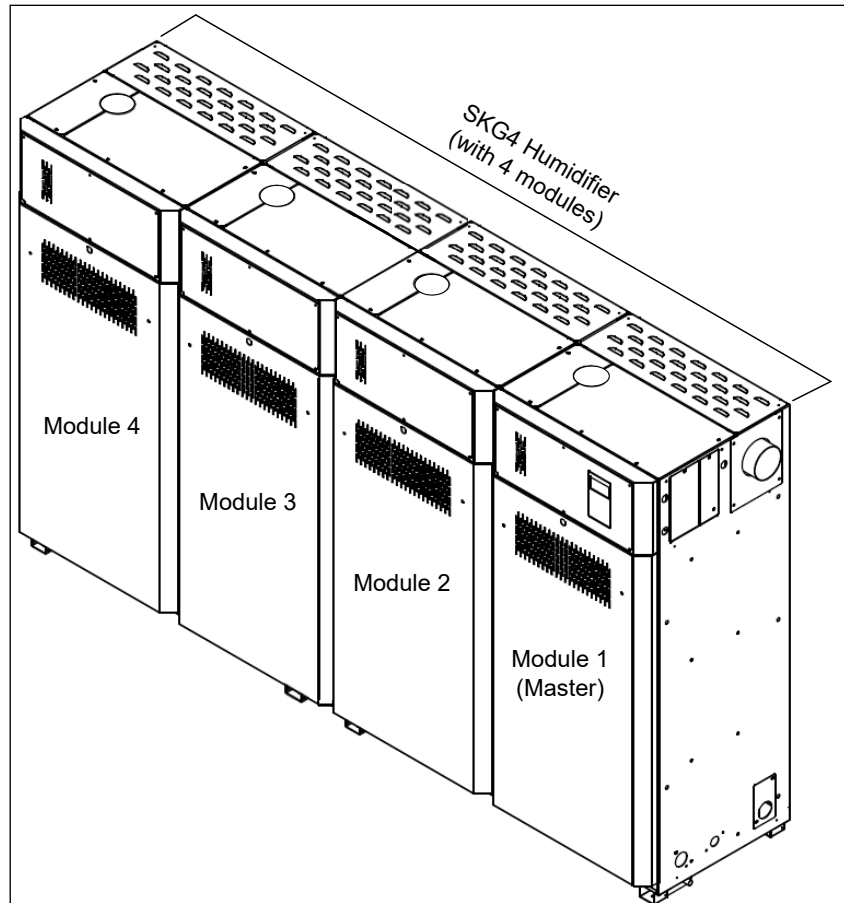

Illustration 7 - Multiple Module Humidifier



Table 6 - Multiple Module Composition

Model	No. of Modules	Module Model Number and Quantity			
		SKG100	SKG150	SKG180	SKG200
SKG4-E0501 N/P	1	x1			
SKG4-E0701 N/P	1		x1		
SKG4-E0801 N/P	1			x1	
SKG4-E1001 N/P	1				x1
SKG4-E1202 N/P	2	x1	x1		
SKG4-E1502 N/P	2		x2		
SKG4-E1702 N/P	2		x1		x1
SKG4-E2002 N/P	2				x2
SKG4-E2503 N/P	3		x1	x1	x1
SKG4-E2703 N/P	3		x1		x2
SKG4-E3003 N/P	3				x3
SKG4-E3504 N/P	4		x1	x1	x2
SKG4-E3704 N/P	4		x1		x3
SKG4-E4004 N/P	4				x4



Installation Overview

Installation Method Statement



WARNING: Risk of electric shock. Disconnect the appliance from electric supply before commencing installation.



Note: All installation work must conform to local codes and regulations.

All work related to the installation of the SKG4 humidifier MUST only be performed by skilled and qualified technical personnel (e.g. qualified gas installer, fitters, electricians, plumbers or technicians with appropriate training).

The customer is responsible for ensuring their suitability.

For the installation of the SKG4 humidifier and its associated components, no special tooling is required above that of a fitter's toolkit.

Installation Steps

- Stage 1: Unit Positioning and Mounting
- Stage 2: Steam Distribution Installation
- Stage 3: Gas Supply Connection
- Stage 4: Water Supply Installation
- Stage 5: Water Drain Connection
- Stage 6: Combustion Air Installation
- Stage 7: Flue Gas Venting Connection
- Stage 8: Electrical Supply and Installation
- Stage 9: Electrical Control Connections

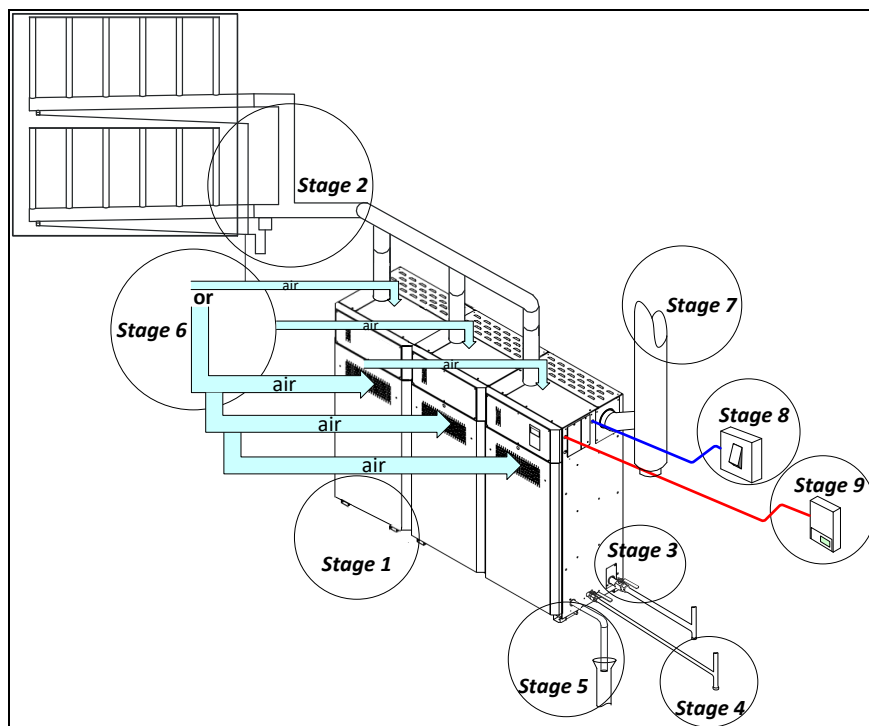

Illustration 8 - Installation Overview



Stage 1 - Unit Positioning and Mounting

General Recommendations



Any installation work **MUST** be carried out by suitably qualified personnel.

Location

Consider the following points before deciding the location for the SKG4 humidifier:

- Locate the SKG4 humidifier in an area clear of combustible materials, gasoline, and other flammable vapours and liquids. Do not install in potentially explosive or flammable atmospheres laden with grain dust, sawdust, or similar airborne materials.
- If the appliance is installed in an insulated area, it must be kept free and clear of insulating materials, as they may be combustible. If insulation is added after the humidifier is installed, an inspection of the humidifier area must be carried out to ensure that there is no insulation coming into contact with the humidifier.
- Provide adequate room ventilation air in accordance with local codes and regulations. With the exception of ducted combustion air installation, do not locate units in tightly sealed rooms or small compartments without provision for adequate air for combustion and room ventilation.
- Combustion and ventilation air must be supplied through one permanent low-level and one permanent high-level opening communicating directly with the outside air.
- Humidifier flue gases must be vented to the outdoors. Locate the humidifier as near as possible to an outside wall or roof so that the flue pipe from the humidifier is short and direct.
- Locate the SKG4 humidifier on a water proof floor or install a drain pan beneath the humidifier.
- The humidifier must be installed in a way that ensures the steam hose length is kept to the shortest possible length.
- Consider the total steam line length between the humidifier and the steam distributor based on the steam line material type:
 - For flexible steam hose, total steam line must not exceed 5 meters. For longer distances, use insulated hard piping.
 - For insulated hard piping, the total steam line is determined by the humidifier capacity: 0.67 m for each kg/hr capacity of the humidifier, with a maximum of 15 m. For longer steam line runs, consult factory.
- The humidifier must be installed in a way that ensures the steam hose length is kept to the shortest possible length.
- The humidifier must be located in an area that is fully accessible for inspection and servicing. Observe the minimum clearances as shown in the following sections.

Positioning

- The humidifier is designed to be installed directly on the floor.
- The humidifier is provided with adjustable legs in order to ensure proper level (standard enclosure only).
- Provide a level, solid foundation for the humidifier.
- Ensure that the floor beneath the humidifier is water proof to withstand any water spillage during servicing or in the event of a problem.



Ambient Condition and Altitude

- The humidifier location **MUST** have an ambient temperature of less than 40°C.
- If the above condition is not respected for indoor humidifiers, the warranty of the unit will be void, as it has not been designed to operate under extreme external conditions.
- For humidifiers having the weather proof enclosure, ensure that the humidifier is installed in a location in which the outside temperature lies between -40°C and 50°C.
- The combustion burner of the SKG4 humidifier is self-adjusting for any altitude; the burner will maintain proper combustion and low emission at any altitude.
- Steam capacity will be affected by altitudes over 1050m above sea level. Please refer to the table below to anticipate the ratio of output reduction.

Table 7 - Output Reduction Based on Altitude

Altitude Above Sea Level (m)	Output Reduction (%)
0 to 1050	0
1051 to 1350	2
1351 to 1650	4
1651 to 1950	6
1951 to 2250	8

Minimum Clearances

- The following minimum clearances are indicated for inspection and servicing access. The SKG4 humidifier is designed for a zero clearance to combustibile materials.
- Leave a clearance of at least 0.8 m to the front panel and 0.6 m on the left and right sides of the humidifier.
- Leave a clearance of at least 0.5 m on top of the humidifier to ensure that there are no obstacles in the way that would prevent the disassembly of components during servicing.

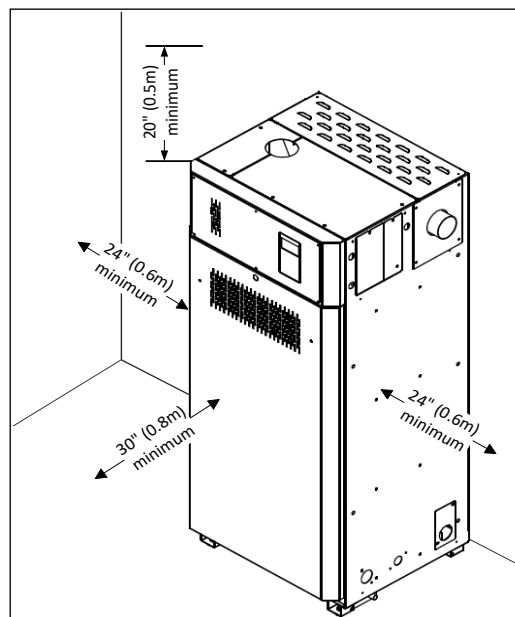

Illustration 9 - Standard Enclosure Clearances



Minimum Clearances - Weather Proof Enclosure

- The following minimum clearances are indicated for inspection and servicing access. The SKG4 humidifier is designed for a zero clearance to combustible materials.
- Leave a clearance of at least 0.8 m to the front panel and 0.6 m on the left and right sides of the humidifier.
- Leave a clearance of at least 0.5 m on top of the humidifier.

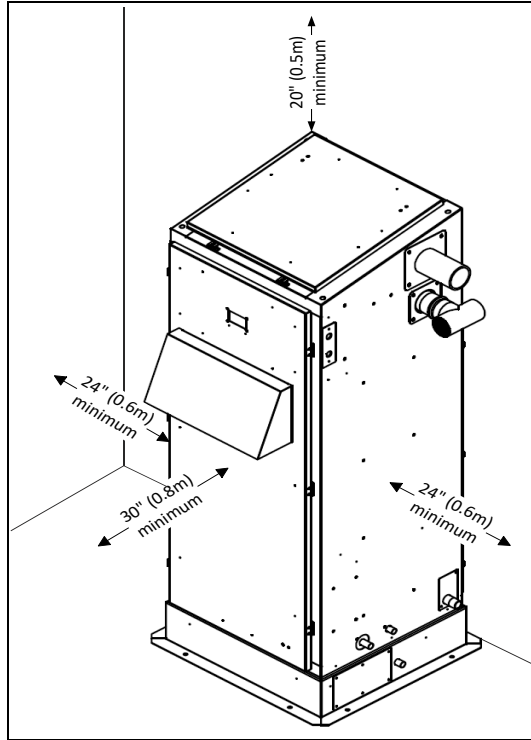

Illustration 10 - Weather Proof Enclosure Clearances



Weather Proof Enclosure Installation on Floor/Roof

The base of the SKG4 humidifier must be secured to the floor/roof using 12mm diameter bolts and washers (not supplied). Use the provided 12mm diameter holes to secure the SKG4 humidifier to the floor/roof.

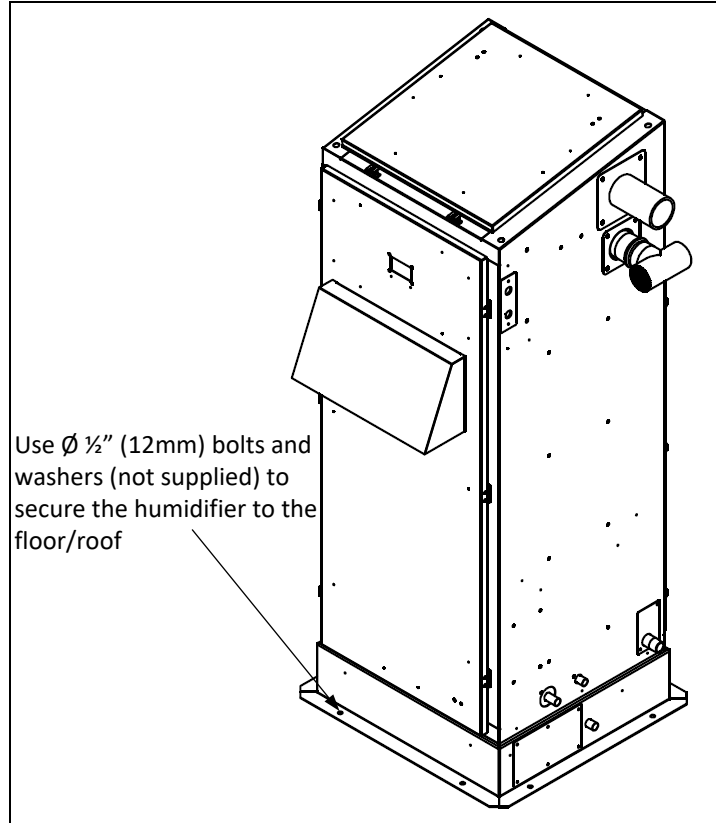

Illustration 11 - Floor/Roof Installation

Weather Proof Enclosure Installation on Roof Curb

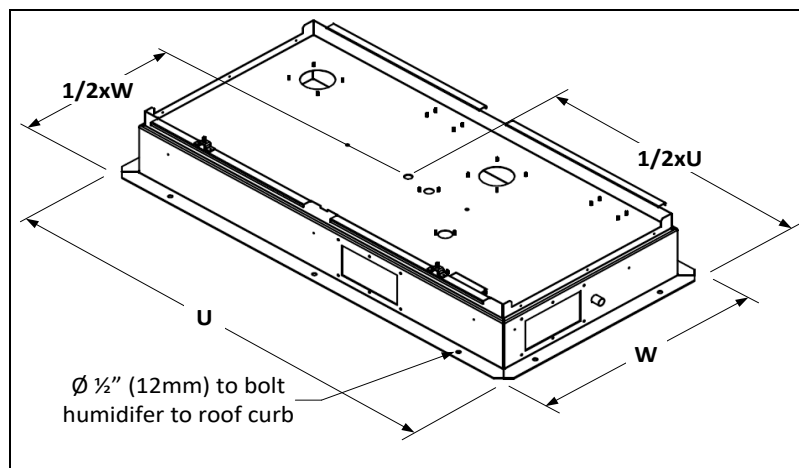

Illustration 12 - Roof Curb Installation

Ensure that the roof curb is structurally built to support the weight of the SKG4 humidifier. The roof curb must provide proper level to the humidifier. The base of the weather proof enclosure is provided with holes of 12mm diameter to secure the SKG4 humidifier to the roof curb, with the use of bolts and washers of 12mm diameter (not supplied).



Stage 2 - Steam Distribution Installation

Fundamental Design Concepts

Follow these general installation rules to avoid any restrictions inside the distribution pipes and the humidifier, as well as condensation accumulation, which can lead to severe water accumulation in the duct or a humidifier malfunction.



CAUTION: Risk of malfunction. Avoid kinks, sags and areas where condensate can be trapped.

- Ensure that the minimum steam pipe gradient must be 2% downward and 15% upward, i.e. 20 mm per 1m run and 150 mm per 1m run to ensure continuous drainage of condensation back to the humidifier or to a steam trap.
- The total length of flexible steam hoses must not exceed 5 m. For insulated rigid piping, it must not exceed 15 m.
- The lowest point of any steam hose or rigid pipe must be the humidifier. If the humidifier cannot be the lowest point of the piping, install one or more steam traps (S Type) at the lowest point(s) of the steam supply piping. The steam separator (S trap) must be installed higher than the static pressure of the system by at least 51 mm.
- Use rigid copper piping whenever possible. Flexible steam hoses can be used for short runs (up to 5 m) or for interconnecting between rigid pipe runs. Ensure that there are no kinks and that the hose does not sag when using flexible tubing. Do not use flexible hoses for curved portions of the steam line.
- When using rigid copper pipe, insulation must be used to diminish condensation build up.
- Leave a minimum distance of at least 25mm before adding any insulation on the steam distribution pipes, to allow the top panels to be easily removable during servicing.

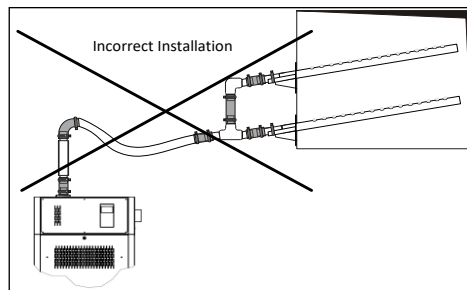

Illustration 13 - Steam Distribution Pipes: Incorrect Installation

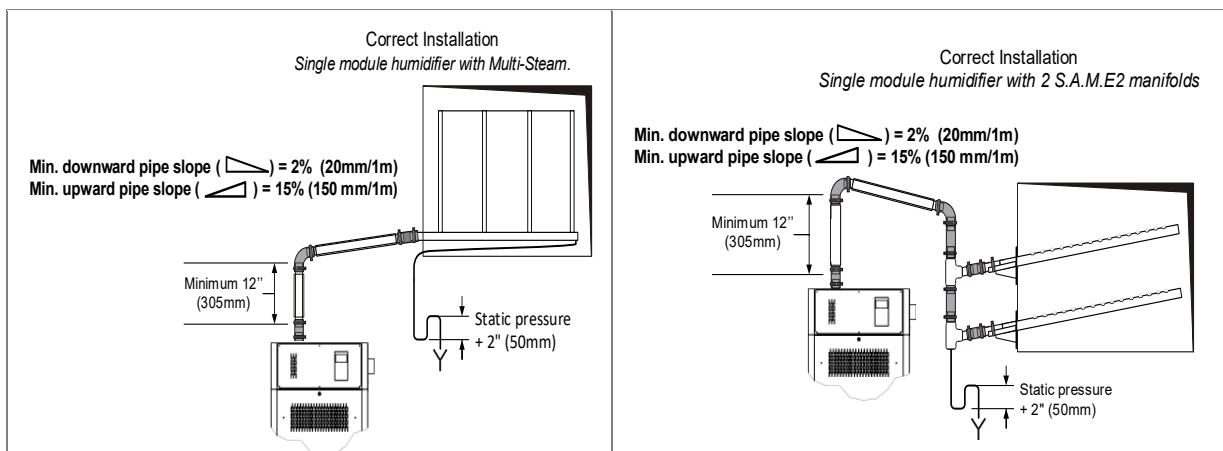

Illustration 14 - Steam Distribution Pipes: Correct Installation



Weather Proof Enclosure Steam Outlets

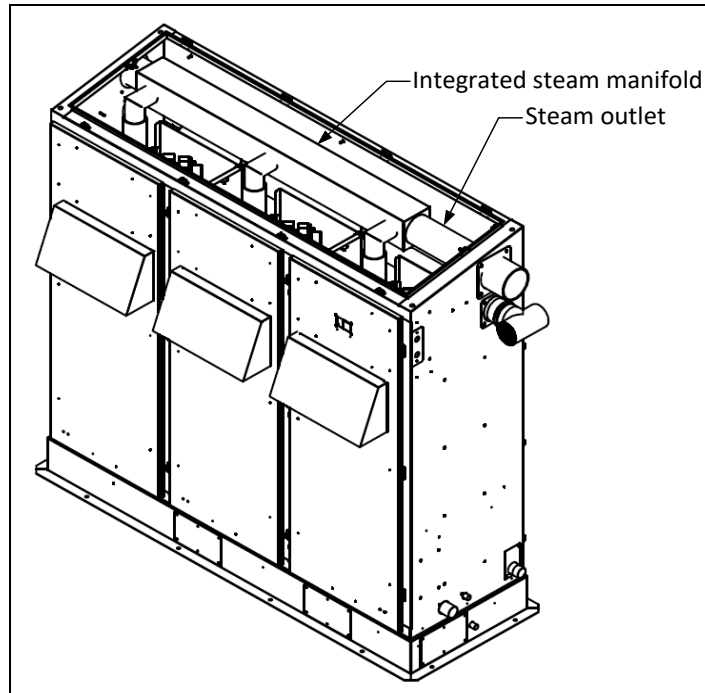

Illustration 15 - Weather Proof Enclosure Single Steam Outlet

The SKG4 humidifier with weather proof enclosure is provided with an integrated steam manifold with an outlet located on either one of the sides of the humidifier.

By default, the steam outlet will be on the right side of the humidifier (when facing the control panel). The steam outlet location can be switched to left side upon request to factory.

Steam Outlet Dimension and Quantity - Weather Proof Enclosure

Table 8 - Steam Outlet Dimensions and Quantity (Weather Proof Enclosure)

Model	Steam Outlet Quantity	Steam Outlet Diameter
SKG4-E0501 to 1001	1	Ø76mm
SKG4-E1202 to 2002	1	Ø100mm
SKG4-E2503 to 3003	1	Ø125mm
SKG4-E3504 to 4004	2	Ø100mm

Steam Dispersion General Recommendations

Follow these general rules based on the steam capacity of the humidifier:

- The connection pipe sizes between the SKG4 and the steam distributor in the duct must be:
 - 76mm up to 100kg/h
 - 100mm up to 200kg/h
 - 125mm up to 300kg/h
- For all humidifiers having a capacity below 100kg/h, use standard Neptronic S.A.M.E2 steam distribution pipes. A Multi-Steam system can be offered if shorter absorption distances are required.
- For all humidifiers having a capacity above 100kg/h, use the Multi-Steam system.
- For all humidifiers having a capacity above 300kg/h, use 2 Multi-Steam units per air handling unit (AHU) or air duct with an equal duty split to each Multi-Steam system.

Selection of Steam Distribution Manifolds

- The minimum steam manifold length that can be used with the models SKG4-E0501 to SKG4-E1001 is 900mm. Any manifold below this dimension will have insufficient outlet spigots to allow proper steam distribution.
- If the duct has a width below 900mm, it will be necessary to either fit multiple pipes or use a Multi-Steam system.

S.A.M.E2 System

Positioning the S.A.M.E2

The steam manifold must be mounted and secured through the side of the air handling unit or duct. Ensure that provisions are made for safe accessibility, ideally with an observation light and window. Ensure that the construction of the duct wall is suitable enough to support the steam pipe for the duration of the installation life.

The dimension of the hole size in the duct must be as follows:

Steam Manifold Ø	Hole Size ØA
54 mm	76 mm

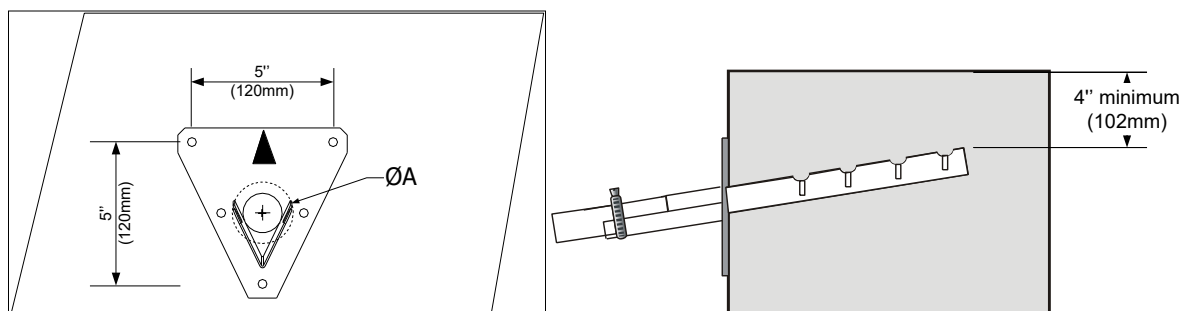

Illustration 16 - Duct Hole Dimensions and Minimum Distance



WARNING: Risk of condensation. Ensure that the minimum distance at the end of the manifold is at least 102 mm from the top of the duct.



Placement of Steam Pipe in Horizontal Duct

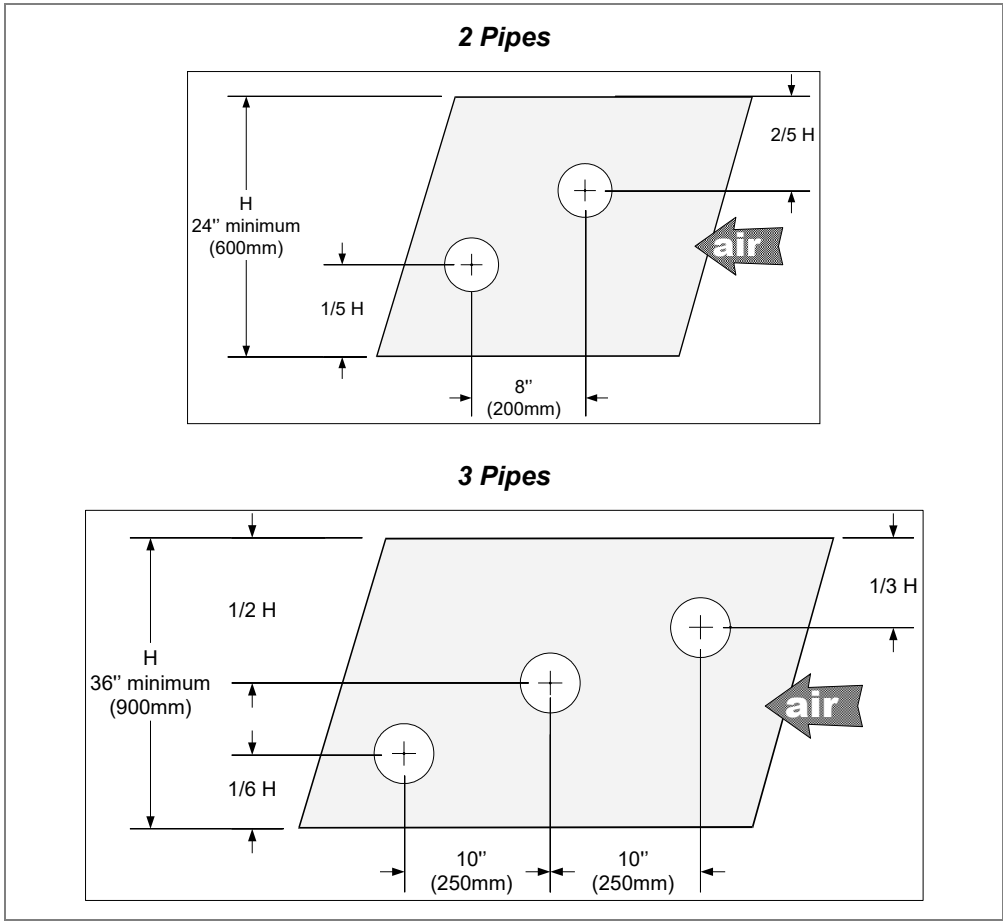

Illustration 17 - Pipe Placement: Horizontal Duct



Note: Steam pipe must be supported on the end by appropriate duct hanger or strap (supplied by others).

Placement of Steam Pipe in Vertical Duct

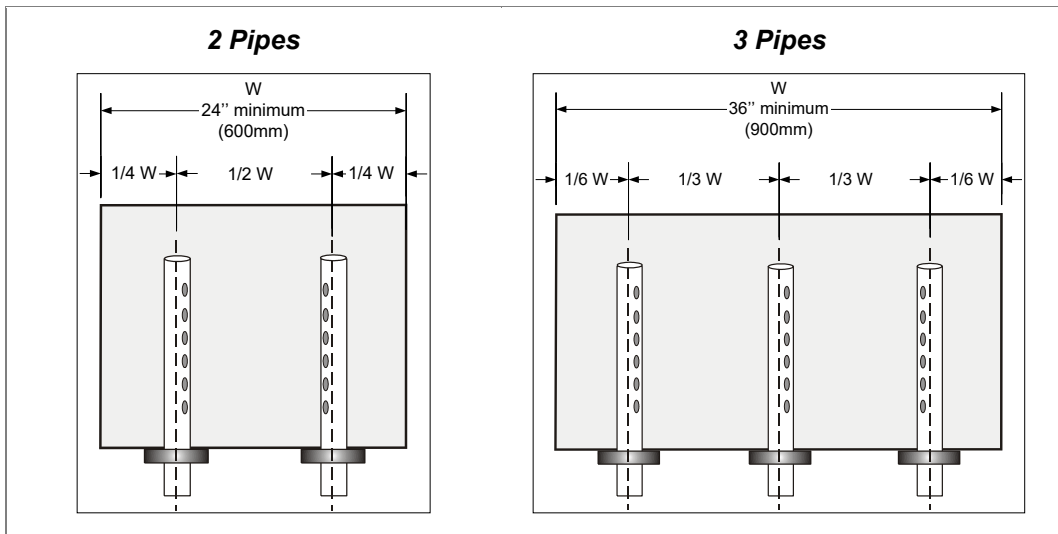

Illustration 18 - Pipe Placement: Vertical Duct



Steam Pipe Work to Duct Connections with S.A.M.E2

Single Module Humidifier: SKG4-E0501

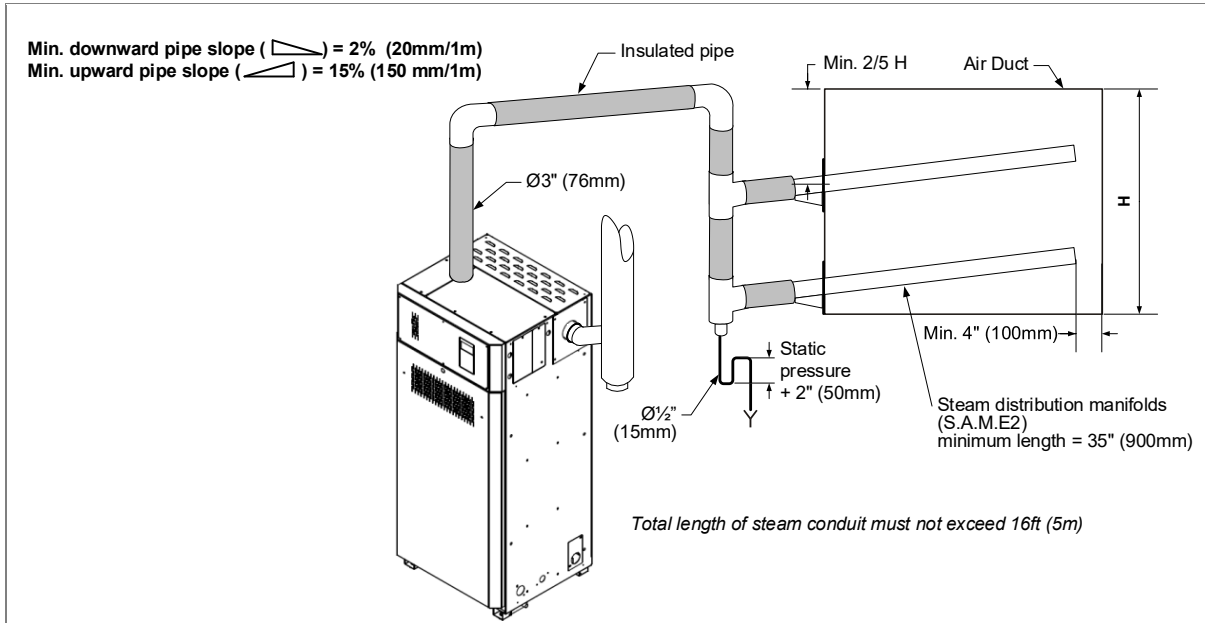

Illustration 19 - S.A.M.E2 Steam Pipe Work (SKG4-E0501)

A single Ø76mm feed pipe must be connected to two S.A.M.E2 steam manifolds with a suitable reduction at the lowest point to allow a Ø15mm condensate drain from the main steam supply.

Single Module Humidifiers: SKG4-E0701 to SKG4-E1001

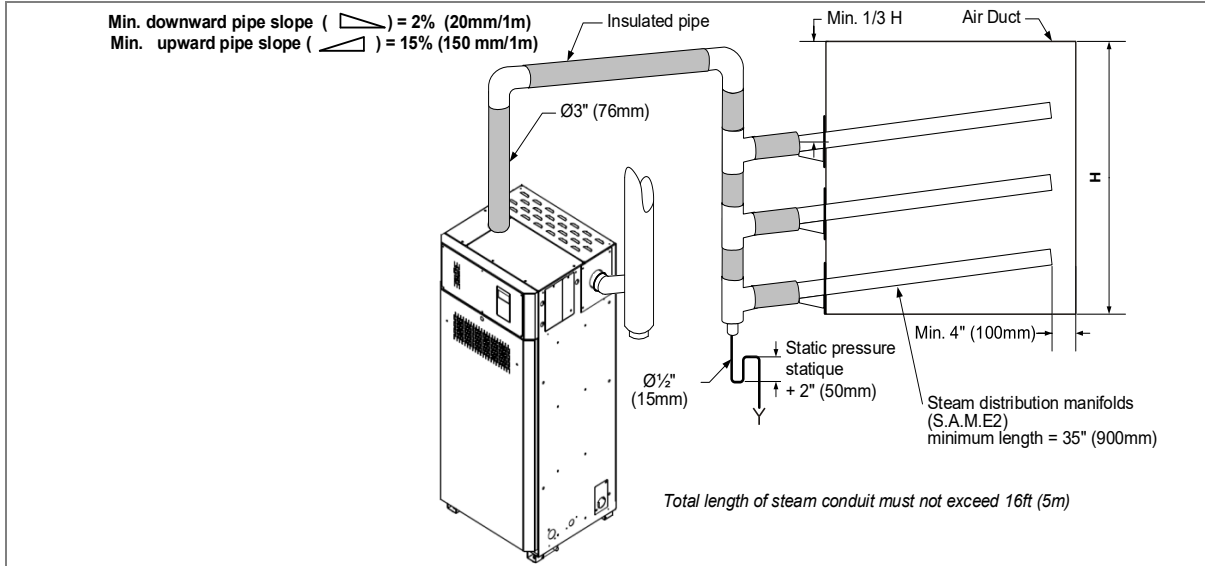

Illustration 20 - S.A.M.E2 Steam Pipe Work (SKG4-E0701 to 1001)

A single Ø76mm feed pipe must be connected to three S.A.M.E2 steam manifolds with a suitable reduction at the lowest point to allow a Ø15mm condensate drain from the main steam supply.



Multi-Steam System

Selection of Multi-Steam System

- For all Multi-Steam units, use the Neptronic Humidisoft program to size the unit.
- Where two Multi-Steam units are required (duties in excess of 300kg/h), make your selection using the following rules:
 - Divide the air volume flow in half.
 - Divide the AHU / air duct **width** in half.
 - **Height** of the duct must remain at 100% its height.
 - This will size the Multi-Steam units so that they can be placed side by side.
- For installation of Multi-Steam units, refer to the Neptronic Multi-Steam Installation Instructions.

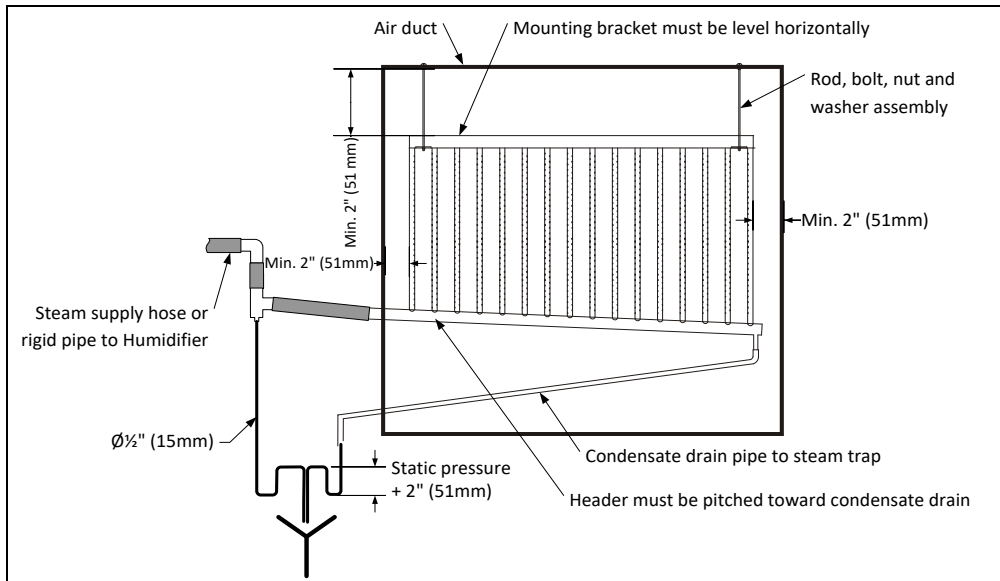

Illustration 21 - Multi-Steam (Horizontal Duct)

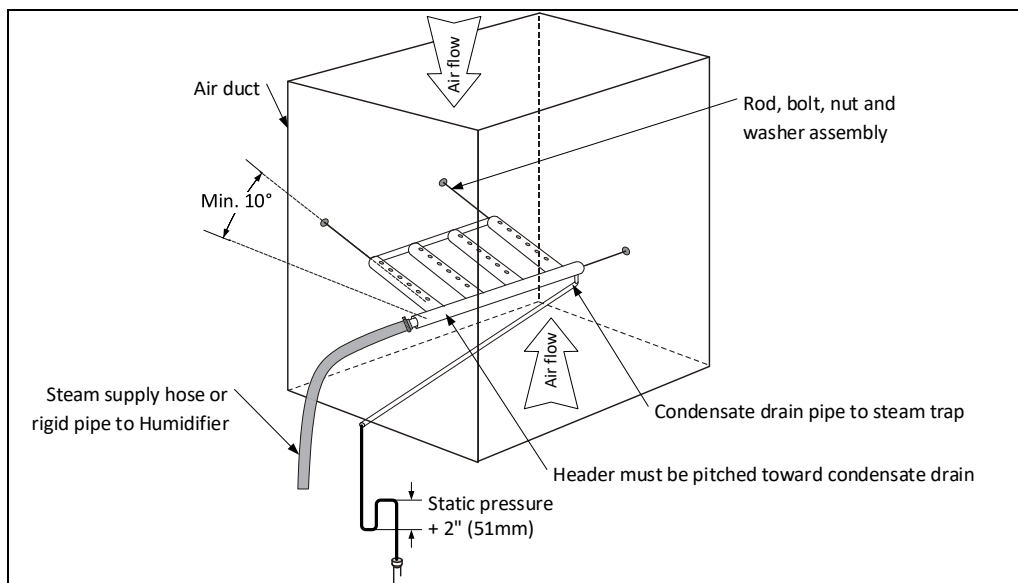

Illustration 22 - Multi-Steam (Vertical Duct)



Steam Pipe Work to Duct Connections with Multi-Steam

Single Module Humidifiers: SKG4-E0501 to SKG4-E1001

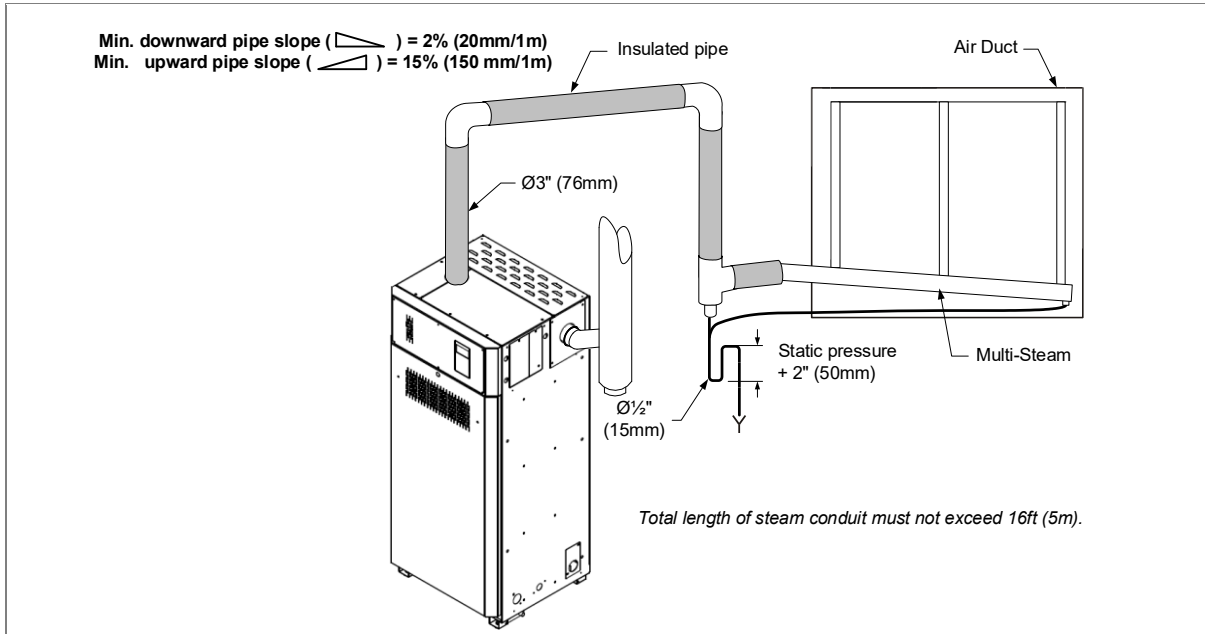

Illustration 23 - Multi-Steam Steam Pipe Work (SKG4-E0501 to 1001)

A single Ø76mm feed pipe must be connected to a single Multi-Steam with a suitable reduction at the lowest point to allow a Ø15mm condensate drain from the main steam supply.

2 Module Humidifiers: SKG4-E1202 to SKG4-E2002

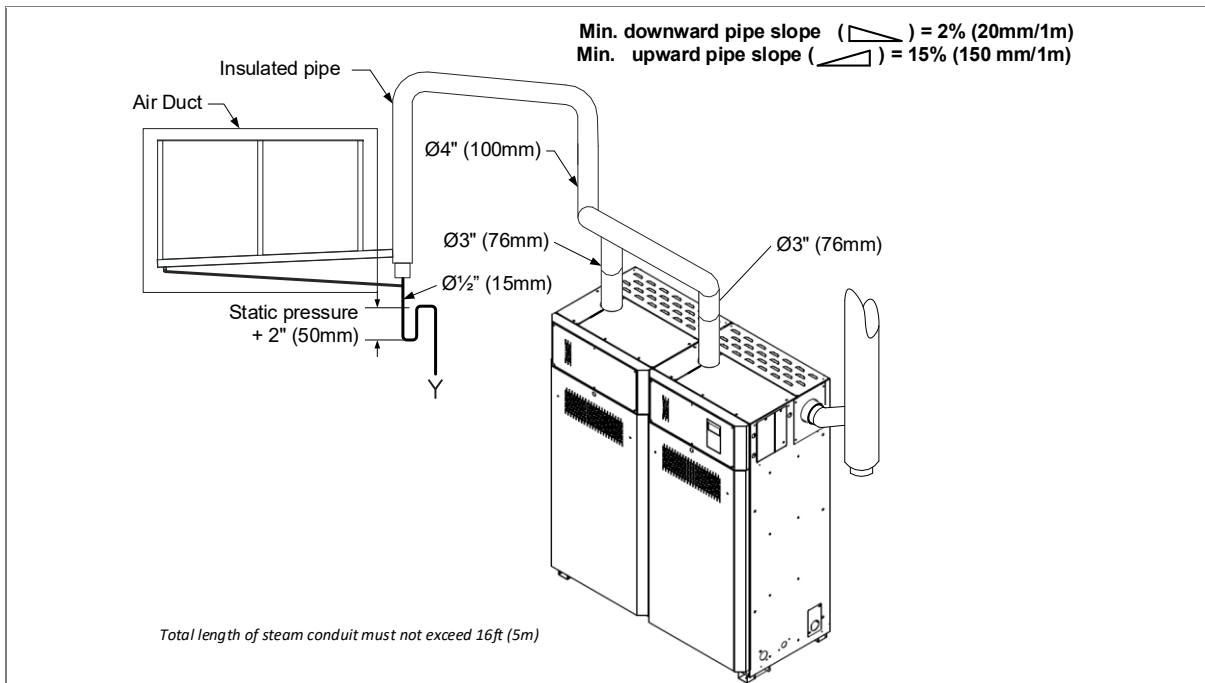

Illustration 24 - Multi-Steam Steam Pipe Work (SKG4-E1202 to 2002)

Two Ø76mm steam outlets attached to a single Ø100mm feed pipe must be connected to a single Multi-Steam with a suitable reduction at the lowest point to allow a Ø15mm condensate drain from the main steam supply.



3 Module Humidifiers: SKG4-E2503 to SKG4-E3003

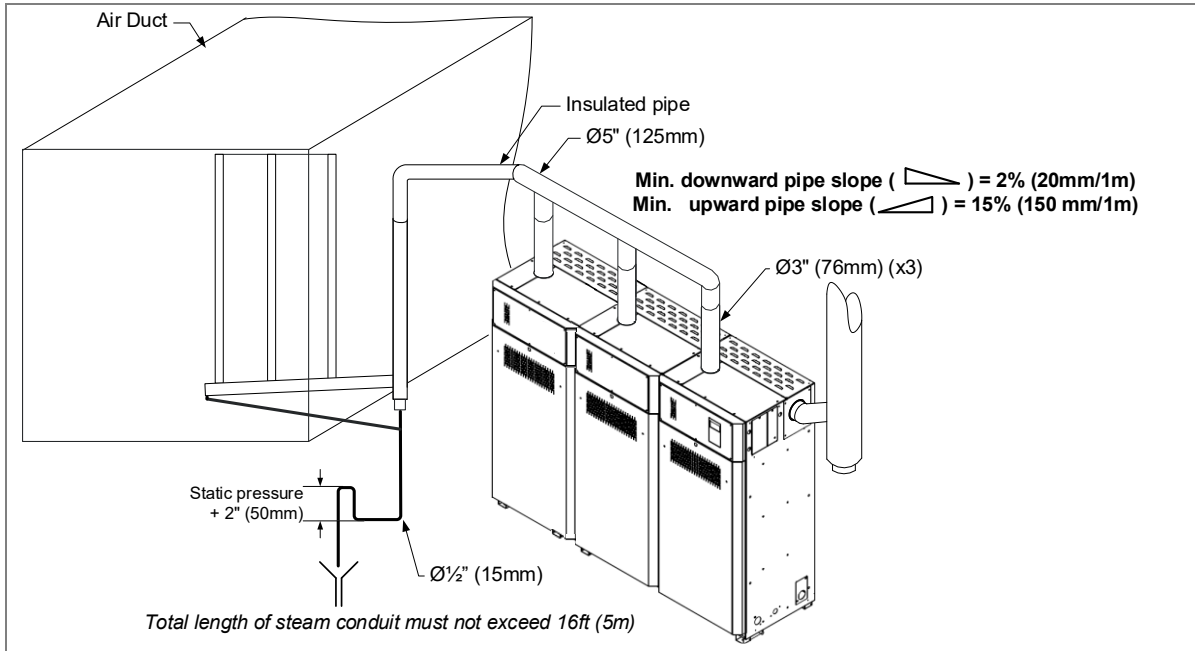

Illustration 25 - Multi-Steam Steam Pipe Work (SKG4-E2503 to 3003)

Three Ø76mm steam outlets attached to a single Ø125mm feed pipe must be connected to a Multi-Steam with a suitable reduction at the lowest point to allow a Ø15mm condensate drain from the main steam supply.

4 Module Humidifiers: SKG4-E3504 to SKG4-E4004

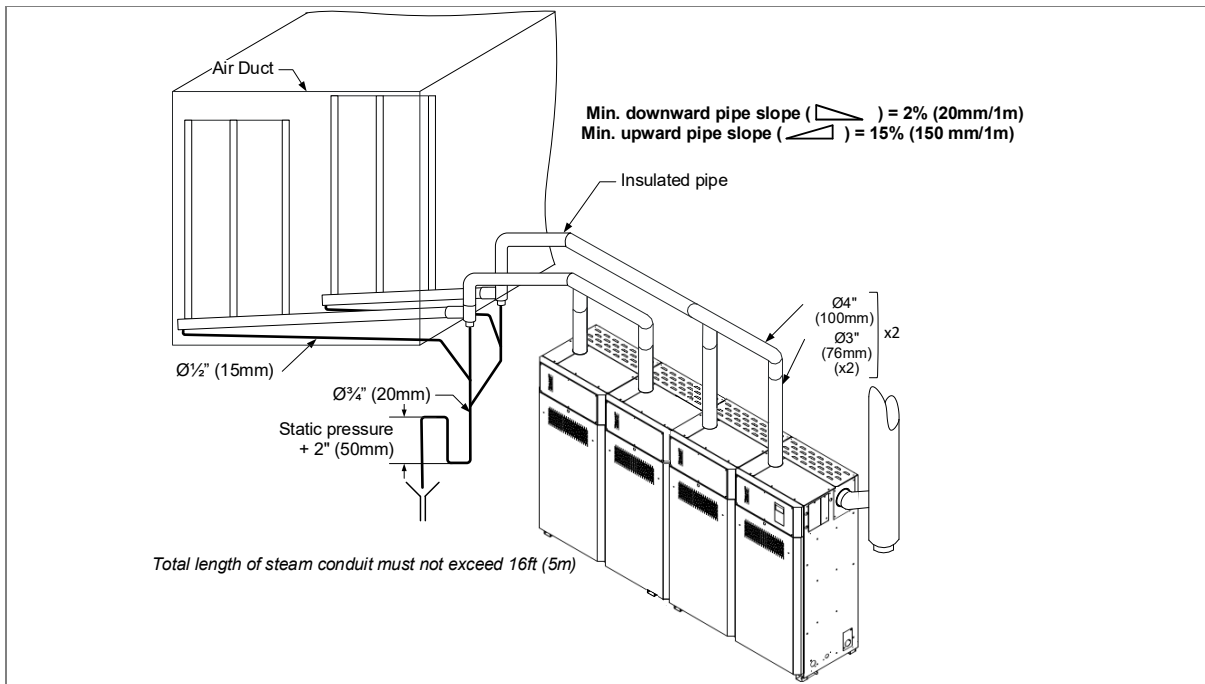

Illustration 26 - Multi-Steam Steam Pipe Work (SKG4-E3504 to 4004)

Two Ø76mm steam outlets attached to a single Ø100mm feed pipe must be connected to a single Multi-Steam with a suitable reduction at the lowest point to allow a Ø15mm condensate drain from the main steam supply. This must be reproduced two times.

If the two Ø15mm condensate pipes are connected, the common condensate drain must be Ø20mm.



Stage 3 - Gas Supply Connection



Gas piping installation must comply with all local codes and regulations.

Any installation work must be carried out by suitably qualified personnel.

- Gas pressure to the humidifier must never exceed 6kPa (60 mbar).
- A manual shut off valve (not supplied) must be installed on the gas supply line to the humidifier. Ensure adequate size for the gas supply line.
- A DN6 (1/8" NPT) plugged tapping for test pressure gauge connection must be installed immediately upstream of the gas supply line. Pressure tapings for test gauges must be located at the gas valve.
- It is recommended to use a separate pressure regulator for each Neptronic SKG4 humidifier connected to the gas line. Ensure that the SKG4 humidifiers are not connected to the same regulator as any other gas appliances.
- Pipes must be inspected for dirt and chips after threading and reaming the end of pipes.
- Gas piping installation must be supported to avoid mechanical strain/stress.
- Two wrenches must be used when connecting gas piping to the humidifier.
- Drip pocket must be provided at any low spot in the gas line.
- Minimum gas pipe gradient must be 6.5mm per 1000mm horizontal run.
- Air purge must be done by disconnecting piping at the gas valve. Air purge must not be done at the heat exchanger of the humidifier.
- After installation, field piping and humidifier gas train must be checked for leaks. Do not use soap solution or open flame on the humidifier gas train. A gas leak detector must be used.
- All leaks must be sealed prior to commissioning the humidifier.

Gas Pipe Diameter

Table 9 - Gas Connection Size

<i>Model</i>	<i>Gas Connection Size</i>
SKG4-E0501 to 2002	Ø25mm Male
SKG4-E2503 to 4004	Ø40mm Male

Refer to local codes and regulations regarding the type and volume of gas handled, in order to obtain the pressure drop allowed in the gas line and determine the gas pipe diameter.

When multiple SKG4 humidifier modules are installed, consideration must be taken to total capacity, gas flow and length of main.

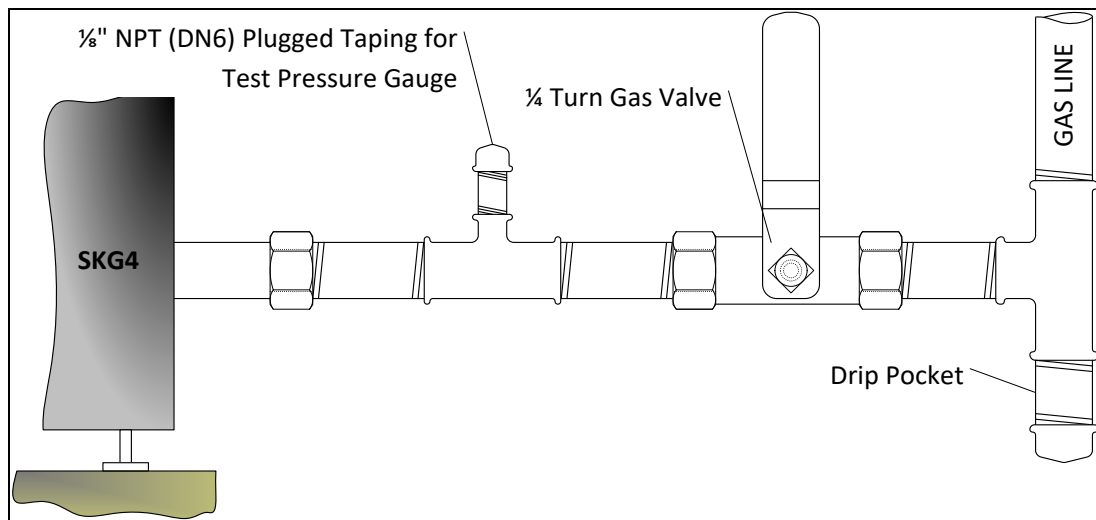

Illustration 27 - Gas Supply Connection

Gas Leak Test

- Pressure testing of the gas supply piping must be performed by the gas installer in accordance with local codes and regulations.
- Test pressure must be relieved from the gas piping system prior to opening the manual shut-off valve of the humidifier.
- For any test pressure over 350kPa (3.5 bar), the humidifier must be disconnected (at the gas shut-off valve).
- The gas supply pressure at the inlet pressure tap, when all the burners are running, must be:
 - 1.75 kPa (17.5 mbar) for natural gas.
 - 3.5 kPa (35 mbar) for propane and butane.



Stage 4 - Water Supply Installation



Water supply installation must conform to Local and National Codes. Any installation work must be carried out by suitably qualified personnel.

Water Inlet Specifications

The SKG4 humidifier is designed to be used with tap, reverse osmosis and deionised water.

- For normal operation, pre-treatment of water is not necessary.
- As the humidifier is equipped with the Neptronic Anti-Foaming Energy Conservation (AFEC) system, which drains the humidifier in the presence of foam to ensure clean and safe operation, the use of softened water is not required.

If a third party requires a water softener for any operational or equivalency purposes, ensure that the water dilution feature is enabled. To enable this function, configure the value of the *BlowdownRate* setting located in the *Installation* menu (see page 57 for details).

- Water Inlet Specifications:
 - Maximum water supply pressure: 170 to 480kPa
 - Minimum water temperature: 4°C
 - Maximum water temperature: 30°C

Chloride Concentration in Water Supply

The presence of chlorides (Cl-) can cause corrosion to the humidifier components that operate at elevated temperatures, such as the evaporation chamber. Damage from corrosion is not covered under warranty.

Here are some general guidelines to follow for chloride concentration based on the type of water used:

Water Source	Chloride (mg/L or PPM)
RO/DI	< 5
Softened	< 30
Tap	< 50

Water Treatment Guidelines

Water treatment, such as reverse osmosis and deionization, can dramatically reduce the service requirements of the humidifiers in hard water environments. The use of purified water allows for longer operation time in between drain intervals, which can be important for maintaining humidity control in high-demand applications.

Here are some general guidelines to follow in regard to water treatment:

Total Hardness (mg/L or PPM)	Description	RO Recommended?
<50	Soft	No
61-120	Moderately Hard	Optional (based on application requirements)
120-180	Hard	Yes
181-800	Very Hard	Yes
>800	Extremely Hard	Yes, High-TDS System Required

Supply Line Installation

- To facilitate servicing, a shut off valve (not supplied) must be installed in the water line, within 1 meter of the humidifier.
- It is recommended to install a water hammer arrestor to absorb the hydraulic shock and minimize the water hammer when the fill valve closes. Follow the dimensioning and installation in accordance with the local plumbing code.
- To install the water supply, connect to the male threaded part of the pipe and tighten it.
- For outdoor installations in which the ambient temperature is below 0°C, ensure that all outdoor water supply pipe lines are properly insulated and heat traced in order to prevent freezing.

<i>Model</i>	<i>Water Inlet Connection Size</i>
SKG4-EXXXX	Ø15mm NPT Male

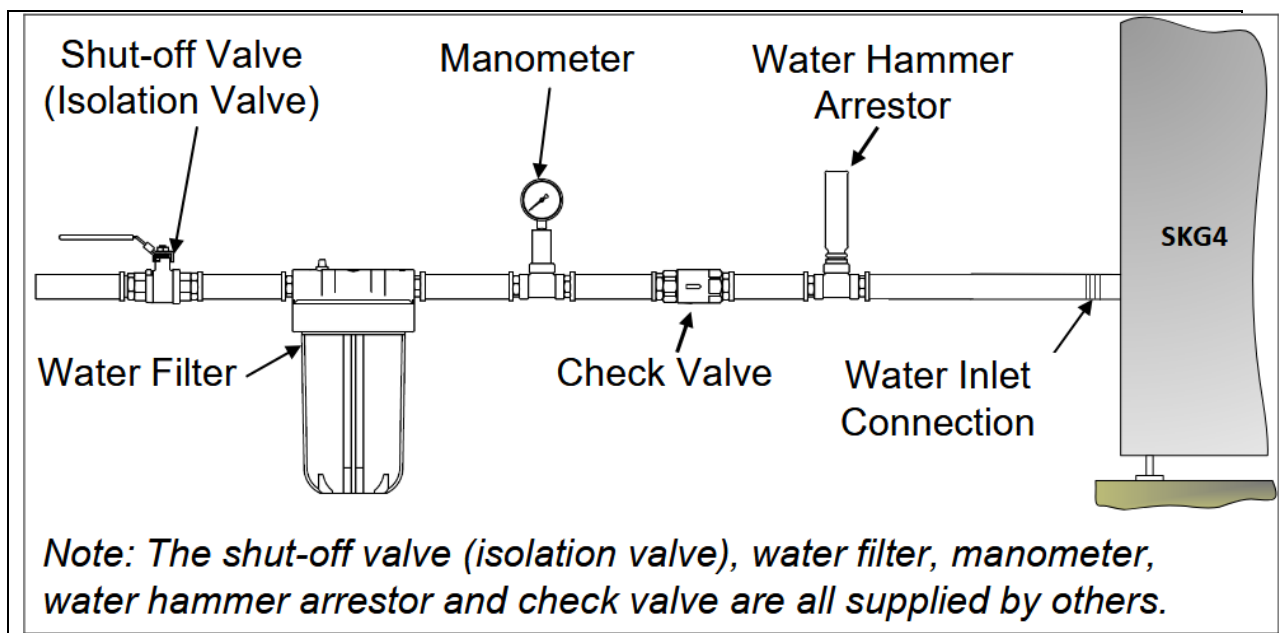

Illustration 28 - Water Supply Connections



Stage 5 - Water Drain Connection



Water drain installation must conform to Local and National Codes.
Any installation work must be carried out by suitably qualified personnel.

Water Drain Specifications

Water drain temperature: 60°C

Model	Water Drain Outlet Connection Size	Pan Drain Outlet Connection Size		Pipe Ø for Length More Than 4.5m	Open Drain Minimum Size
		Standard Humidifier	Weather Proof Enclosure		
SKG4-E0501 to 1001	Ø22mm	Ø18mm	Ø22mm	Ø40mm	Ø80mm
SKG4-E1202 to 2002	Ø36mm			Ø50mm	
SKG4-E2503 to 4004	Ø50mm			Ø80mm	Ø100mm

Water Drain Installation

- Water drain outlet connection must be connected to drain pipe of sufficient size.
- It is recommended to use standard copper or stainless steel hydraulic pipes of sufficient size.
- The installed drain piping must be rated for a temperature of 100°C.
- Minimum water drain pipe gradient must be of 6.5mm per 300mm horizontal run.
- No drain trap must be installed on the humidifier drain pipes.
- The main drain and pan drain must not be piped together or to other appliances.
- The maximum equivalent pipe length of the main drain must not exceed 4.5m between the drain outlet of the humidifier and the open drain. Otherwise, the drain pipe diameter must be increased to the value indicated in the table above.
- The maximum drain flow rate of one SKG4 unit is equivalent to 48 l/min per module.
- A minimum 25mm air gap must be kept between the connection of the humidifier drain pipes and the open drain line.

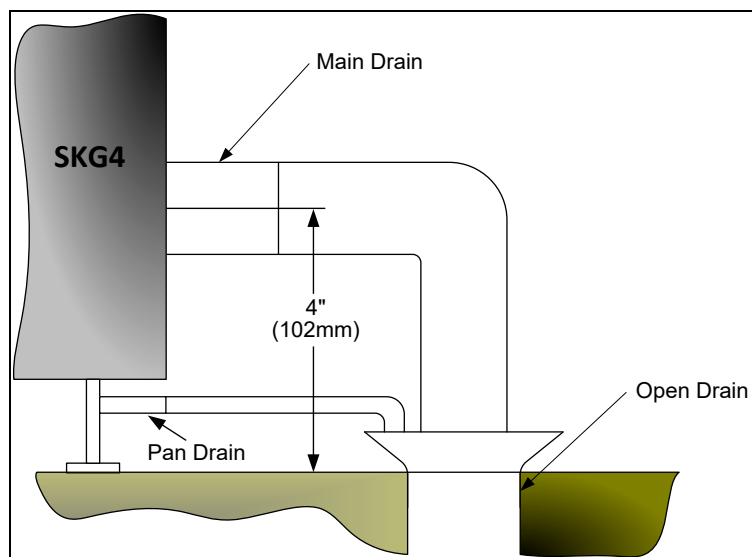

Illustration 29 - Water Drain Connections: Correct Installation

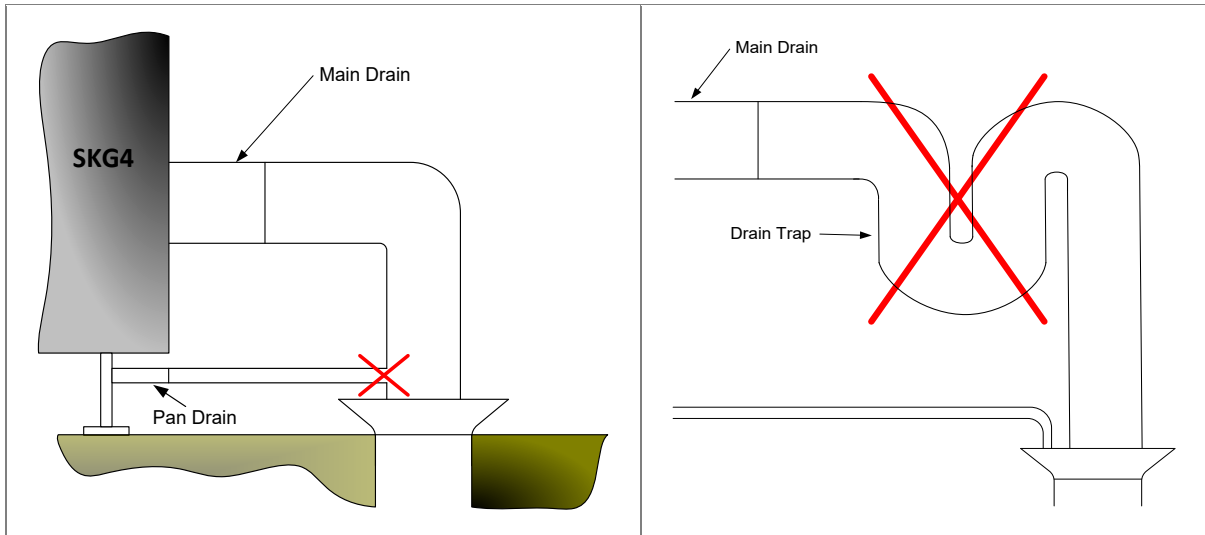

Illustration 30 - Water Drain Connections: Incorrect Installation

Pan Drain Connection on Weather Proof Enclosure

The weather proof enclosure is provided with a pan drain at the base of the SKG4 humidifier.

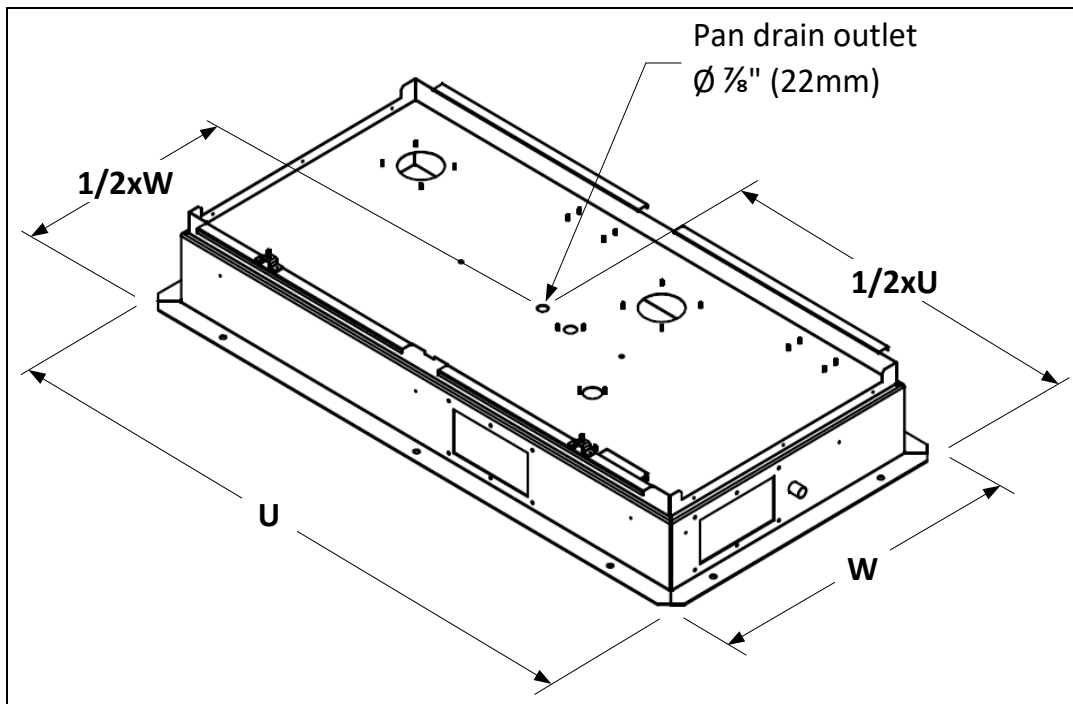

Illustration 31 - Weather Proof Enclosure Base Dimensions

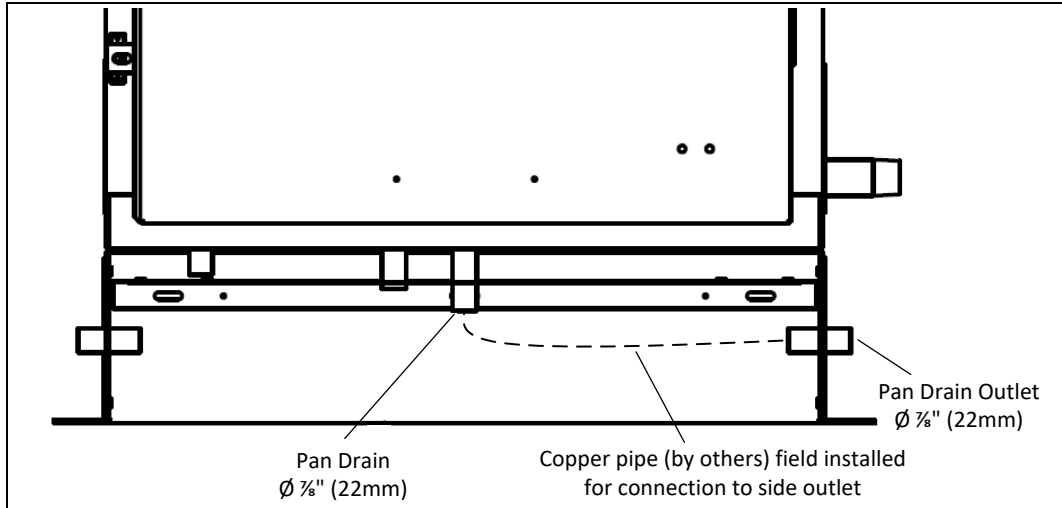

Illustration 32 - Weather Proof Enclosure Plumbing: Front View

Weather Proof Enclosure Water Drain Valve

The weather proof enclosure is equipped with a normally open valve, enabling the humidifier to drain all water during a power failure, in order to prevent water from freezing within the unit. During normal operation, the humidifier reduces drain water temperature to 60°C.



CAUTION: During a power failure, the drain water temperature is not reduced for units with the weather proof enclosure. Installed drain piping must be rated to 100°C.



Stage 6 - Combustion Air Installation



Combustion and room ventilation air must conform to local codes and regulations.

Any installation work must be carried out by suitably qualified personnel.

- Air for combustion must not be contaminated by halogens, ammonia, bromides, chlorides, fluorides, iodides or dust. Excessive exposure of humidifier to these contaminants will result in performance related problems. A humidifier that may be operated in toxic environments must be equipped with ducted combustion air installation.
- The operation exhaust of fans such as ventilation fans or other combustion appliances can create a negative pressure condition on the humidifier. Adequate air supply must be provided for the ventilation devices, in addition to that required by the humidifier.
- Any installation work must be carried out by suitably qualified personnel.
- With the exception of ducted combustion air installation, do not locate units in tightly sealed rooms or small compartments.
- Combustion and ventilation air must be supplied through one permanent low-level and one permanent high-level opening communicating directly with the outside air.
- The location of the air intake(s) must be at a sufficient height above ground level to prevent blocking due to accumulated debris.
- The supply air intake vent(s) must be equipped with a weather cap and bird screen, in order to prevent gusts of wind or water from entering, preventing mold build up or leakage in the ducts.
- The SKG4 humidifier has filtered air openings through the front door. Do not block or obstruct the humidifier air openings.
- The humidifier is factory adjusted for correct performance. Do not alter throttle setting or restrict blower combustion air inlet.

Combustion Air Specification - Natural Ventilation

Table 10 - Natural Ventilation Installation Openings

Model	Number of Modules	Natural Ventilation Installation	
		Minimum Low Level Opening – Inlet (cm ²)	Minimum High Level Opening – Outlet (cm ²)
SKG4-E0501 N/P	1	540	270
SKG4-E0701 N/P	1	558	549
SKG4-E0801 N/P	1	567	554
SKG4-E1001 N/P	1	743	641
SKG4-E1202 N/P	2	770	655
SKG4-E1502 N/P	2	954	747
SKG4-E1702 N/P	2	1031	785
SKG4-E2002 N/P	2	1215	878
SKG4-E2503 N/P	3	1427	983
SKG4-E2703 N/P	3	1503	1022
SKG4-E3003 N/P	3	1688	1114
SKG4-E3504 N/P	4	1899	1220
SKG4-E3704 N/P	4	1976	1258
SKG4-E4004 N/P	4	2160	1350

Note 1: The information contained in the above table is from BS 6644, Specification for the installation and maintenance of gas-fired hot water boilers of rated inputs between 70 kW (net) and 1.8 MW (net).



Note 2: These minimum openings section are specified for the combustion air requirement of the SKG4 Humidifier. If other gas fired appliances are installed in the same room, the openings will have to be increased to be able to supply adequate combustion air for all of the appliances.

Note 3: For comparison with minimum flue gas venting spacing, refer to Stage 7.



Natural Ventilation Installation

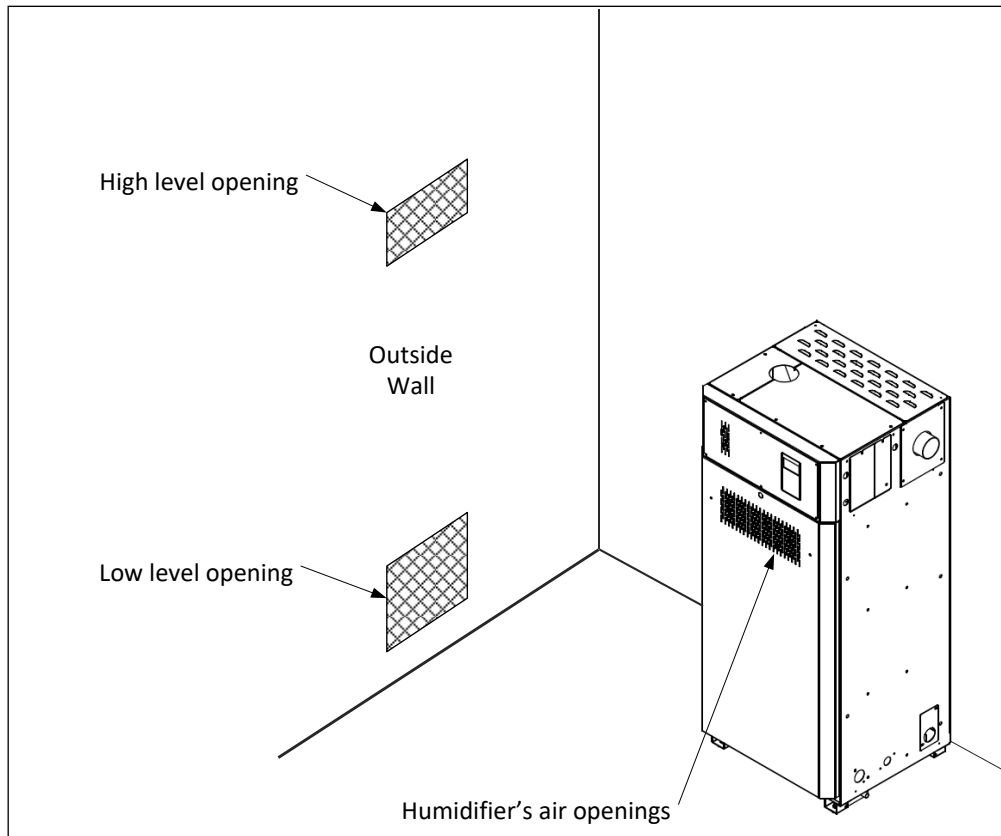

Illustration 33 - Natural Ventilation Configuration

Ducted Combustion Air

- The “Ducted Combustion Air” option, also called Sealed Combustion, is available upon request.
- When the “Ducted Combustion Air” option is installed, the requirements for minimum low level and high level natural ventilation do not apply.
- Installation of the combustion air duct must be as direct as possible, minimizing the number of turns or elbows, with a maximum of 6 elbows in total.
- Use only duct materials suitable to supply air from the outside to the humidifier.
- Combustion air duct length and flue gas venting pipe must not exceed:
 - 30m – 3m x (total number of 90° elbow) – 1.5m x (total number of 45° elbow).
- Combustion air duct must be insulated to avoid condensing around the duct when outside air temperature is below 0°C.
- Ensure that the combustion air duct connections are air tight.
- The minimum combustion air duct upward gradient must be 20mm in 1000mm horizontal run.
- Leave a distance of at least 0.5m between the top of the humidifier and the ducted combustion air manifold to ensure that the manifold does not prevent the disassembly of the humidifier’s components during servicing.
- Leave a minimum distance of at least 25mm before adding any insulation on the ducted combustion air pipes, to allow the top panels to be easily removable during servicing.

Model	Combustion Air Inlet Diameter per Module
SKG4-EXXXX	Ø51mm O.D.



Single Module Humidifiers: SKG4-E0501 to SKG4-E1001

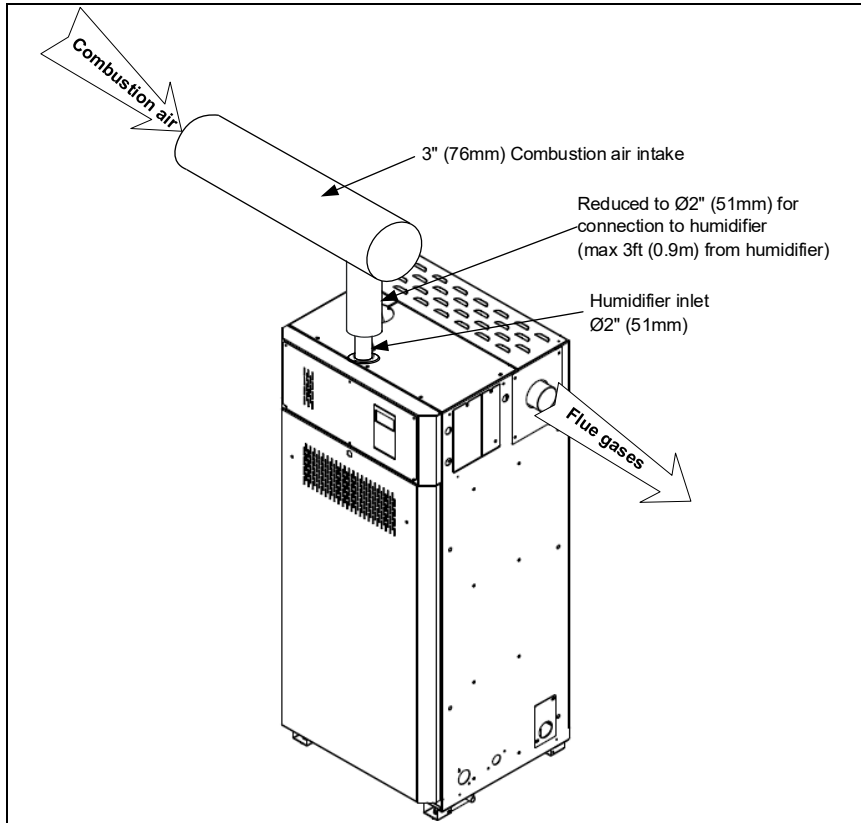

Illustration 34 - Ducted Combustion Air (1 Module)



2 Module Humidifiers: SKG4-E1202 to SKG4-E2002

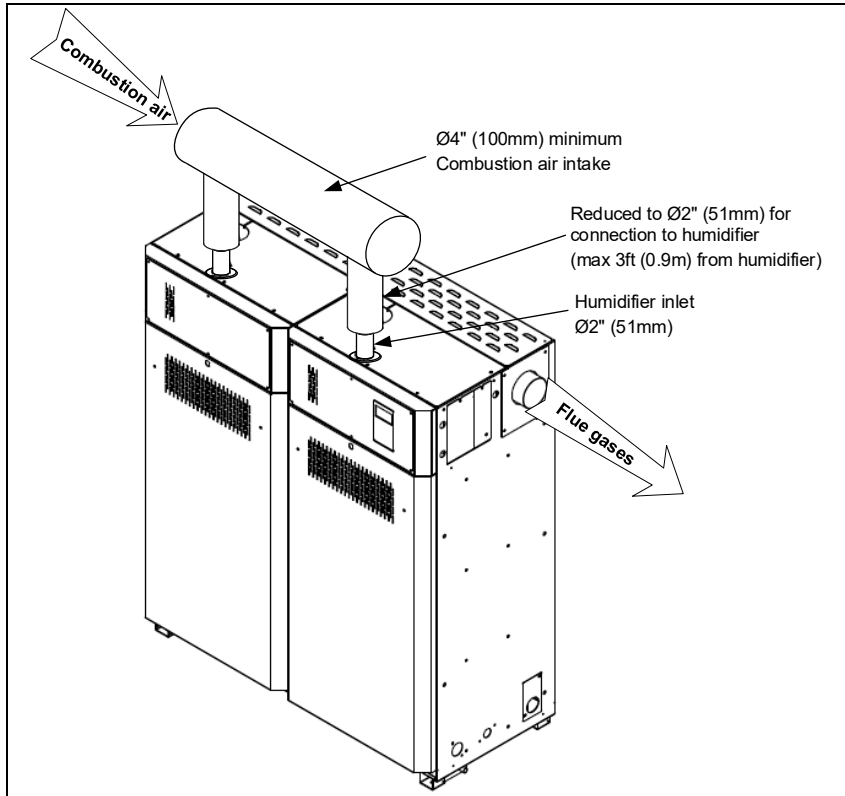

Illustration 35 - Ducted Combustion Air (2 Modules)

3 Module Humidifiers: SKG4-E2503 to SKG4-E3003

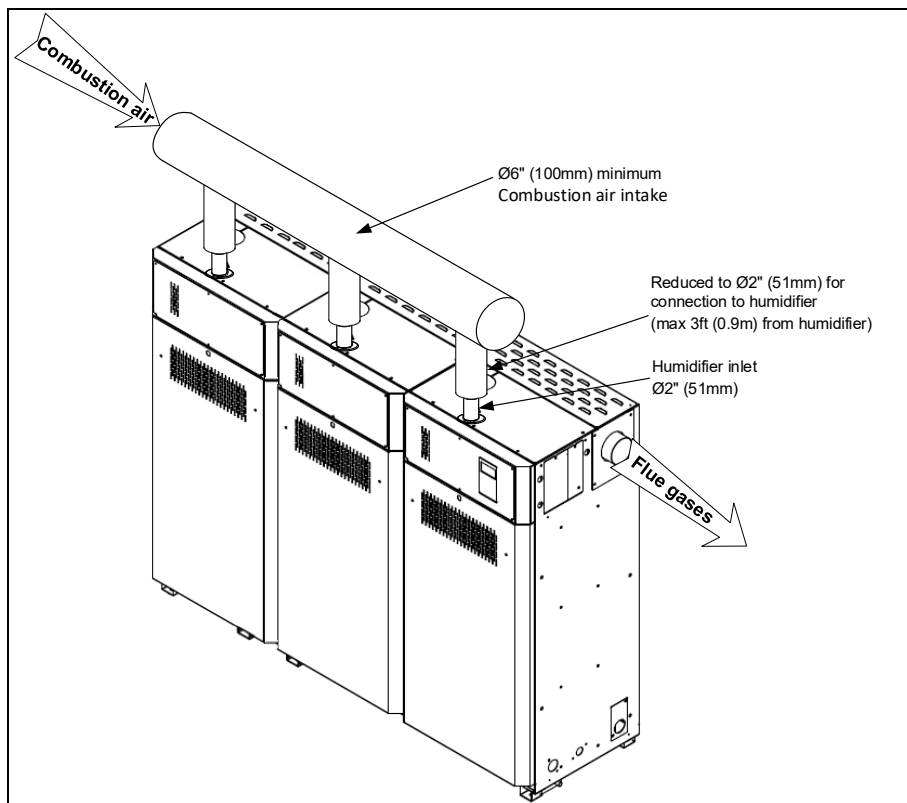

Illustration 36 - Ducted Combustion Air (3 Modules)



4 Module Humidifiers: SKG4-E3504 to SKG4-E4004

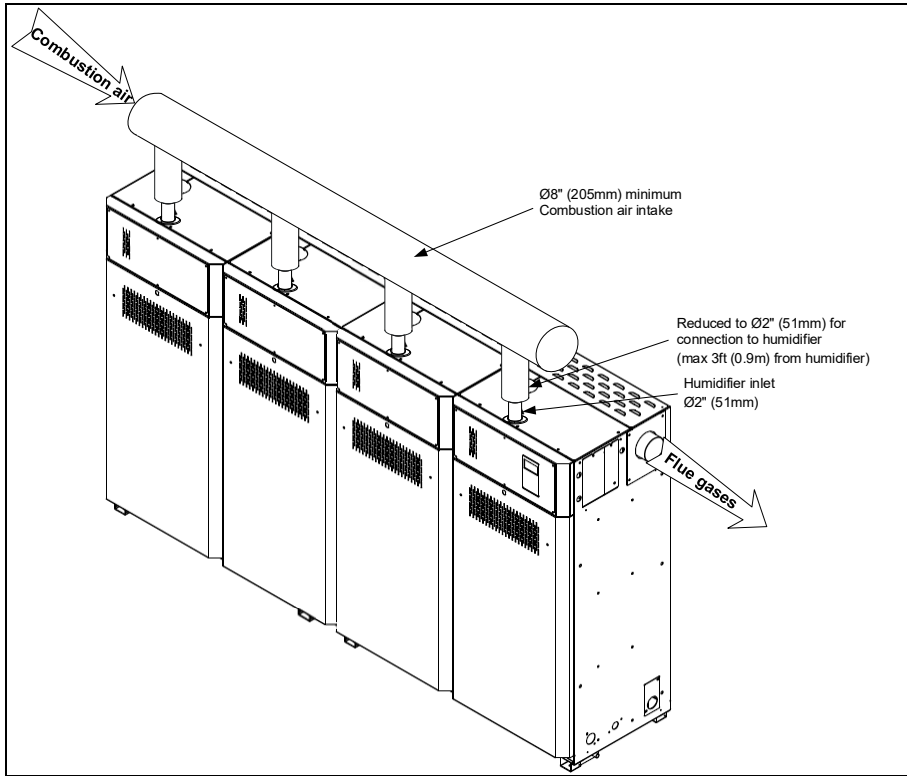

Illustration 37 - Ducted Combustion Air (4 Modules)



Stage 7 - Flue Gas Venting Connection

Flue gas venting must conform to local codes and regulations.



Any installation work must be carried out by suitably qualified personnel.

Install flue gas venting systems in accordance with vent manufacturer's instructions.

- For safe and efficient operation of the SKG4 humidifier, flue gases (product of combustion) must be evacuated through a dedicated flue gas venting system to the outside air.
- Do not vent the SKG4 humidifier into another venting system serving another appliance. The humidifier must be vented by its own approved/listed flue system.
- Any flue gas venting pipes passing through floors, ceilings, and walls must be installed with proper clearances to combustible materials and must be fire stopped according to local codes and regulations.
- Use only roof and wall penetration systems recommended by the flue gas venting system manufacturer.
- Flue gas venting pipe must be free of any restrictions or obstructions. The flue gas venting pipe diameter must be the same as the SKG4 flue gas connector.
- Do not use unlined masonry or concrete chimney as a flue gas venting system.
- The flue gas venting system must not extend into, or pass through, any circulation air duct or plenum.
- Installation of the flue gas venting pipes must be as direct as possible, minimizing the number of turns or elbows, with a maximum of 6 elbows in total.
- If flue gas venting pipe length exceeds 6.1m, it is recommended to install an approved insulated flue gas venting pipe, to reduce the formation of condensate.
- Ensure that the flue connection to the humidifier is air tight. Failure to do this will result in damage due to moist flue gases condensing.

Flue Gas Venting Specification

- The SKG4 humidifier is a fan assisted positive pressure flue gas appliance.
- Maximum flue gas temperature: 200°C.
- Maximum flue gas venting pipe length:
 - 30m - 3m x (total number of 90° elbow) - 1.5m x (total number of 45° elbow).

<i>Model</i>	<i>Single Flue Gas Outlet Diameter</i>
SKG4-E0501 to 1001	Ø76mm O.D.
SKG4-E1202 to 2002	Ø100mm O.D.
SKG4-E2503 to 4004	Ø125mm O.D.

- Flue gas venting pipe diameter must be same as the SKG4 flue gas connector.
- Minimum flue gas venting pipe upward gradient must be 20mm in 1000mm horizontal run or as per flue gas venting manufacturer's instructions.
- The SKG4 humidifier is a non-condensing appliance.
- Condensate drip tee must be installed on chimney as per flue gas venting manufacturer's instructions.



Flue Gas Terminal

- A proper flue gas terminal must be installed to prevent back flow or any other outside weather condition that may affect proper operation of the SKG4 Humidifier.
- Distances from the flue gas venting terminal to adjacent public walkways, buildings, and any open able windows or building opening must conform to local codes and regulations.
- Flue gas terminal must be at sufficient height above the ground level to prevent blocking by accumulated debris. Building materials must be protected from degradation by flue gases.
- Installation of the flue gas venting pipes must be as direct as possible, minimizing the number of turns or elbows, with a maximum of 6 elbows in total.
- Vertical flue gas terminal must extend at least 1 meter above the roof top, and 0.6 meter above any ridge located within 3 meters from the terminal.
- The terminal inlets and outlets from separate combustion and air supply circuits for the supply of combustion air and the evacuation of combustion products must not terminate on different walls of the building.

Minimum Spacing

Table 11 - Minimum Spacing When Flue Gas Terminal is Located Towards Outside Air

Minimum Spacing (mm)	Building or Other Element
300	Below adjacent opening (window, air vent or any other ventilation opening).
75	Below a gutter, drain or soil pipe.
200	Below eaves catch or, balcony.
75	Beside vertical drain or soil pipe.
300	Beside adjacent corner or other flue gas terminal.
150	Beside adjacent opening (door, window, air vent or any other ventilation opening).
300	Above adjacent ground or balcony level.
2100	Above ground level, in areas accessible to public.
1500	Above or below other flue gas terminal.
600	From a surface facing the terminal.
1200	From a facing other flue gas terminal.
1250	Above, below, beside or facing any electric or gas meter, regulator or relief device.

Table 12 - Minimum Spacing When Flue Gas Terminal is Located in Car Port for Residential Building

Minimum Spacing (mm)	Building or Other Element
200	Below car port ceiling.
75	Beside vertical drain or soil pipe.
300	Beside adjacent corner or other flue gas terminal.
1200	Beside adjacent opening (door or window).
300	Above adjacent ground or balcony level.
2100	Above ground level, in areas accessible to public.
1500	Above or below other flue gas terminal.
600	From a surface facing the terminal.
1200	From a facing other flue gas terminal.
1250	Above, below, beside or facing any electric or gas meter, regulator or relief device.

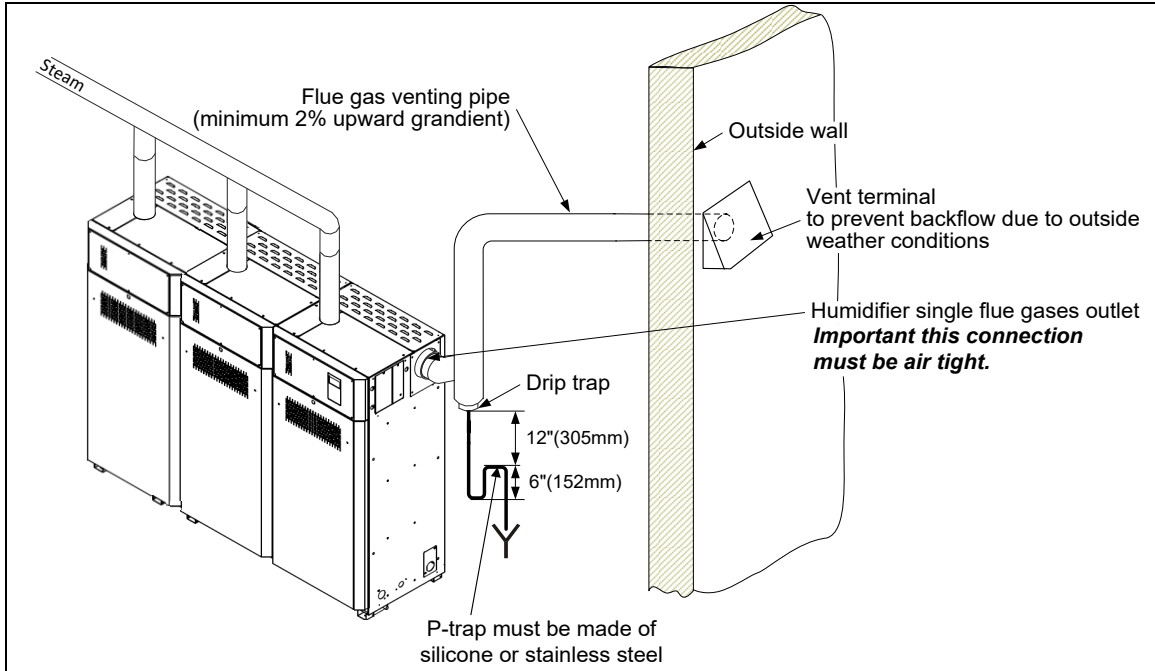

Illustration 38 - Typical Flue Gas Installation (3 Modules)



Stage 8 - Electrical Supply and Installation



CAUTION: Risk of electric shock. Disconnect the humidifier from the electric supply before proceeding with the connection.



All work concerned with electrical installation **MUST** only be performed by a qualified electrician and must conform to the procedure, regulation and local codes.

- Use copper power conductor only.
- All incoming power supplies must be externally fused for over current protection.
- The electrical supply must also be isolated for the purpose of emergency and servicing.
- The isolator must have a contact separation of at least 3 mm.
- An external over current protection and disconnect circuit breaker must be installed on the supply, adjacent to the humidifier.
- To provide strain relief to the supply cable, install a knock-out (not supplied) at the bottom of the electrical compartment of the humidifier.
- Ensure that the size of the wire conductors is appropriate for the maximum current supplied.
- Ensure that the incoming power cable is secured via suitably sized cable gland.
- Ensure that each terminal connection is secured firmly with a cable ferrule.
- The humidifier cabinet has an uninterrupted or unbroken electrical ground. Do not use gas piping as an electrical ground.

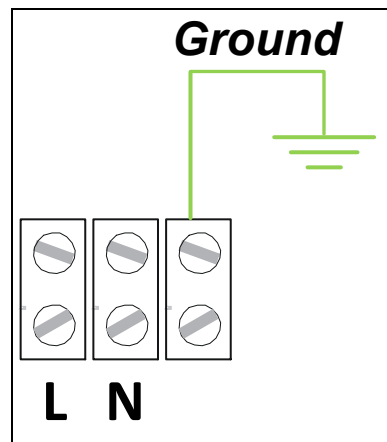

Illustration 39 - Power Supply Connection

Electrical Power Supply

Table 13 - SKG4 Electrical Power Supply

Model	Voltage	Standard	Weather Proof Enclosure
		Current (A)	Current (A)
SKG4-E0501 to 1001	230V - 1ph	3.0	3.6
SKG4-E1202 to 2002	230V - 1ph	4.5	5.8
SKG4-E2503 to 3003	230V - 1ph	6.0	7.8
SKG4-E3504 to 4004	230V - 1ph	7.5	9.5



Stage 9 - Electrical Control Connections

Electrical Control Connections

The SKG4 humidifier has a modulating control system and requires an analog control signal. All controls connections have been grouped on a specific control board.

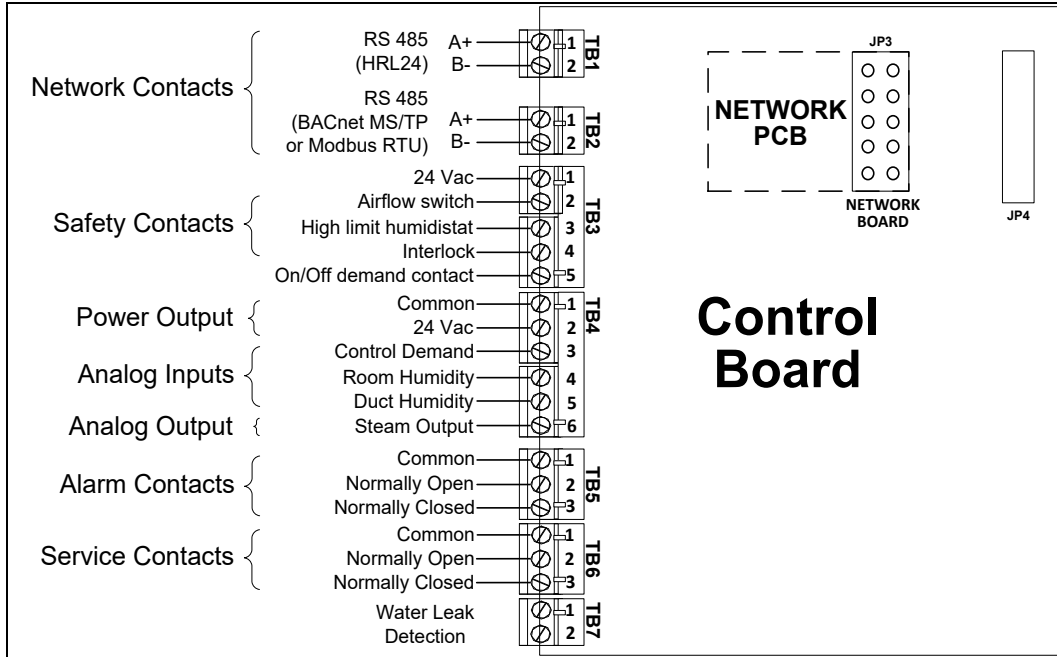

Illustration 40 - Electrical Control Connections

Network Communication (TB1 and TB2)

If the control signal is from a HRL24, connect terminals TB1 1&2 to the network (RS485 A+ & B-).

If the control signal is from a BACnet MS/TP or Modbus RTU network, connect terminals TB2 1&2 to the network (RS485 A+ & B-).

The network control signal must be selected by accessing the *Control* sub-menu located in the *Installation* menu (see page 57). To setup the communication parameters, access the *Integration* menu (see page 61).



Note: BACnet MS/TP is configured by default. To change the communication interface to Modbus RTU, access the NtwrkOption setting located in the Network sub-menu of the Integration menu (see page 61).

Safety Contact Connections (TB3)

The **Airflow switch** contact must be wired between terminals TB3 1&2. If this contact opens, operation of the SKG4 unit will stop. The unit will display the airflow switch as open, but will not generate an alarm. If an airflow switch is not used, install a jumper between terminals TB3 1&2.

The **High limit humidistat** contact must be wired between terminals TB3 1&3. If this contact opens, operation of the SKG4 unit will stop and an **alarm** message will be displayed. If a high limit humidistat is not used, install a jumper between terminals TB3 1&3.

The **Interlock** must be wired between terminals TB3 1&4. If this contact opens, operation of the SKG4 unit will stop. The unit will display the Interlock as open, but will not generate an alarm. If Interlock is not used, install a jumper between terminals TB3 1&4.

The **On/Off demand contact** must be wired between TB3 1&5. When contact is closed, 24V is supplied and the SKE4 unit will operate at 100%. When contact is open it will stop the unit idle state.

**This demand contact only works for the operation of On/Off models.*

Control Analog Connections (TB4)

The control profile and the source of the signals can be configured via **Menu > Installation > Control**. This configuration determines the behavior of **TB4** (see page 56 for more details).

Table 14 - Profile Selection for Control Demand Control Signal

Control Signal	External	Network	ExternNetwork
		Analog	ExternAnalog
	Internal	Network	InternHumNetwork
		Analog	InternHumAnalog

Table 15 - Profile Selection for High Limit

High Limit Signal	External	Network	ExternNetwork
		Analog	ExternAnalog
	Internal	Network	InternNetwork
		Analog	InternAnalog
	Disabled	-	Disabled

Network sourced signals are connected via **BACnet MS/TP** or **Modbus** to **TB2**.

For the external profiles, the control signal is used directly as the demand %.

- The control signal coming from an analog source is connected to **TB4-3**.
- The high limit analog signal is connected to **TB4-5**.

For the internal profiles, the signal will be processed by an internal PID loop to calculate the demand %.

- The R.H.% reading signal is connected to the input **TB4-4**.
- The high limit analog signal is connected to **TB4-5**.
- The control setpoints are to be configured in **Menu > User Settings > Control** (see page 55).
- The PID settings are to be set in **Menu > Installation > Control** (see page 61).

TB4-6 is an analog output, which gives feedback of the % demand at which the unit is currently operating.

Dry Contacts (TB5 and TB6)

Two series of volt free contacts are provided:

1. Alarm Contacts
 2. Service Contacts
- These contacts are used to switch a low voltage, ideally 24V, with a switching current of no more than 3 Amps.
 - Each series has one Normally Closed contact and one Normally Open contact.
 - It is recommended to use the Normally Closed contact, as this contact will open in the event of a humidifier fault.

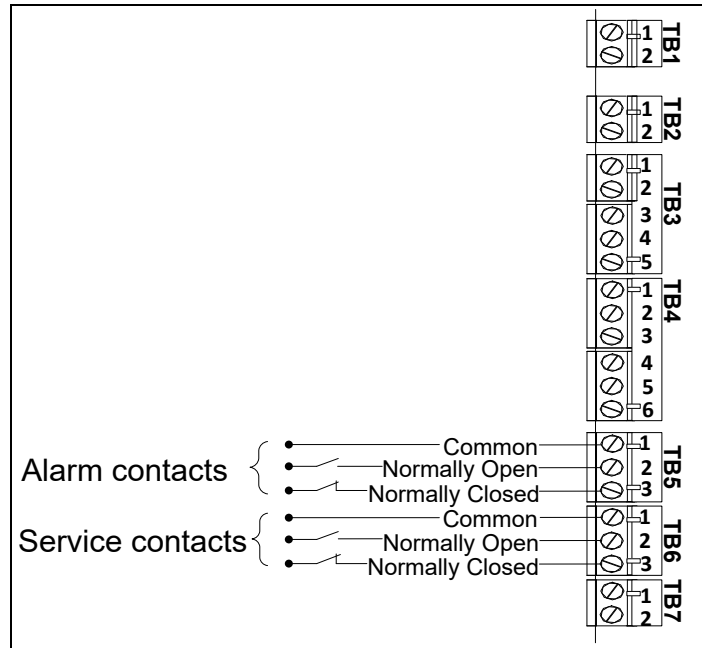

Illustration 41 - Alarm and Service Contact Wiring

Humidifier Control

Analog Signals

For operation of modulating humidifiers, the analog signal(s) must be connected between terminals TB4 1 and TB4 3, 4 and/or 5. To configure the source of the signal(s), access the *Control* sub-menu located in the *Installation* menu (see page 57).

Humidity Control by Humidistat (External Mode)

Humidity controlled externally, using HRO20 humidistat:

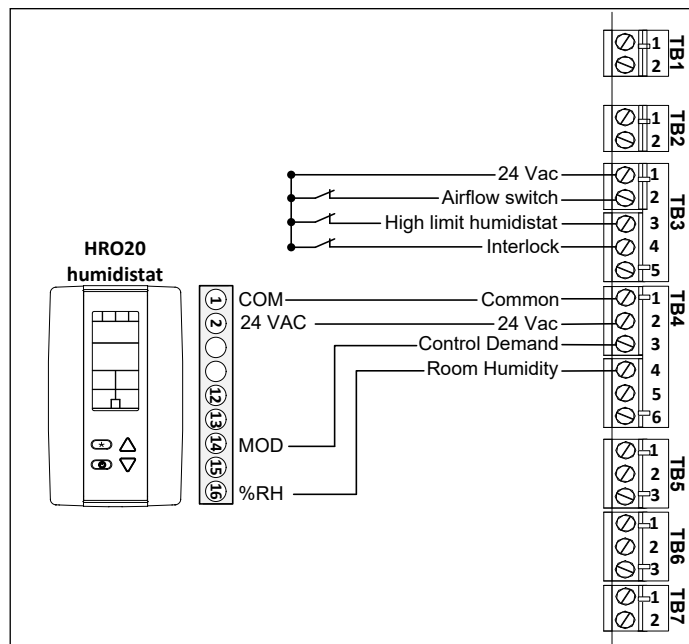

Illustration 42 - Control Signal from HRO20 Humidistat



Humidity controlled externally, using HRO20 humidistat with SHR10 or SHC80 as space sensor:

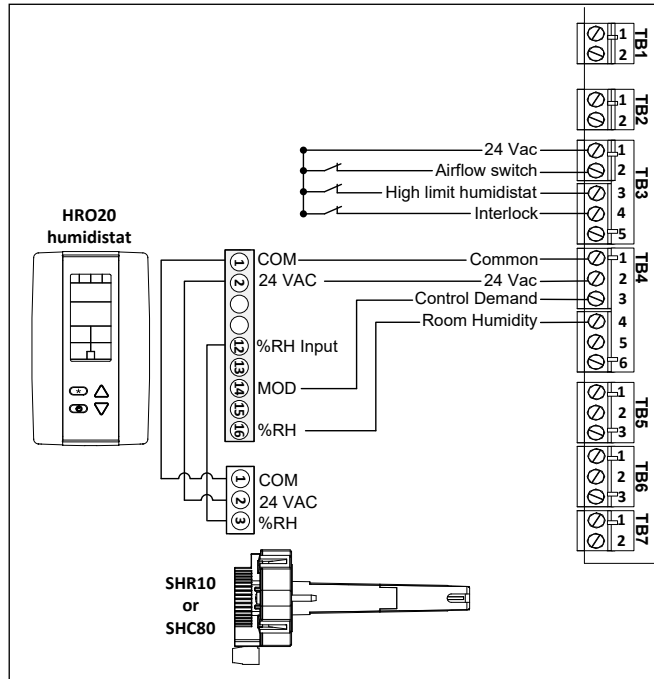

Illustration 43 - Control Signal from HRO20 Humidistat with Remote Humidity Sensor (SHR10 or SHC80)

Humidity Control by Humidifier (Internal Mode)

Humidity controlled internally, using SHR10 or SHC80 as space sensor:

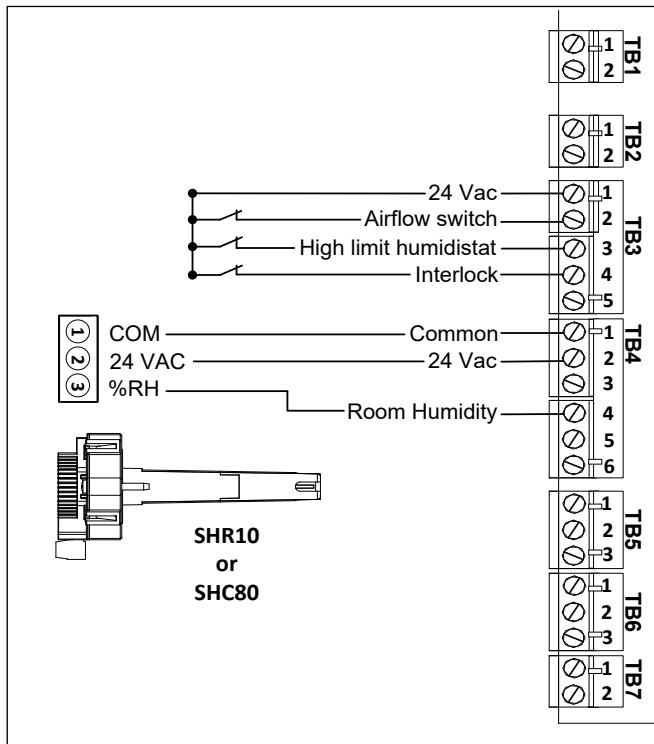

Illustration 44 - Humidity Signal from Remote Humidity Sensor (SHR10 or SHC80)



Humidity Control by External Signal

Humidity controlled externally, using an external signal source:

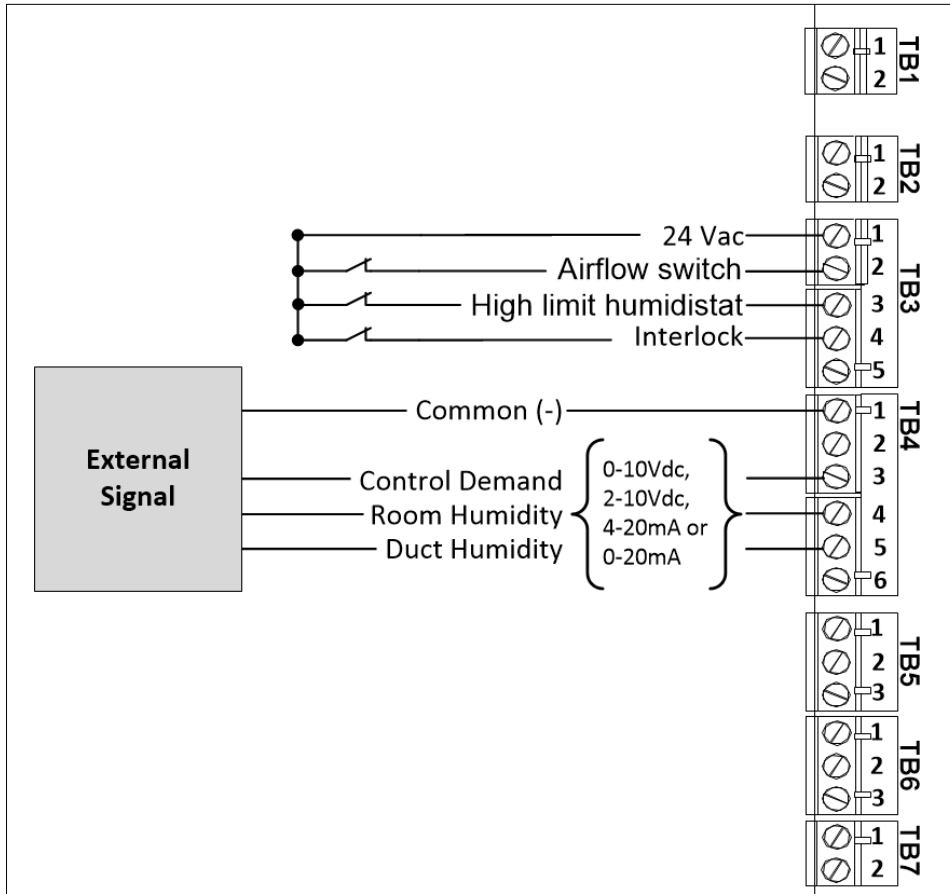

Illustration 45 - Control Signal from External Device



Network Communication

If the control signal is from a BACnet MS/TP or Modbus RTU network, connect terminals TB2 1&2 to the network (RS485 A+ & B-).

If the control signal is from a HRL24, connect terminals TB1 1&2 to the network (RS485 A+ & B-).

The network control signal(s) must be selected by accessing the *Control* sub-menu located in the *Installation* menu (see page 57). To setup the communication parameters, access the *Integration* menu (see page 57).



Note: BACnet MS/TP is configured by default. To change the communication interface to Modbus RTU, access the NtwrkOption setting located in the Network sub-menu of the Integration menu (see page 57).

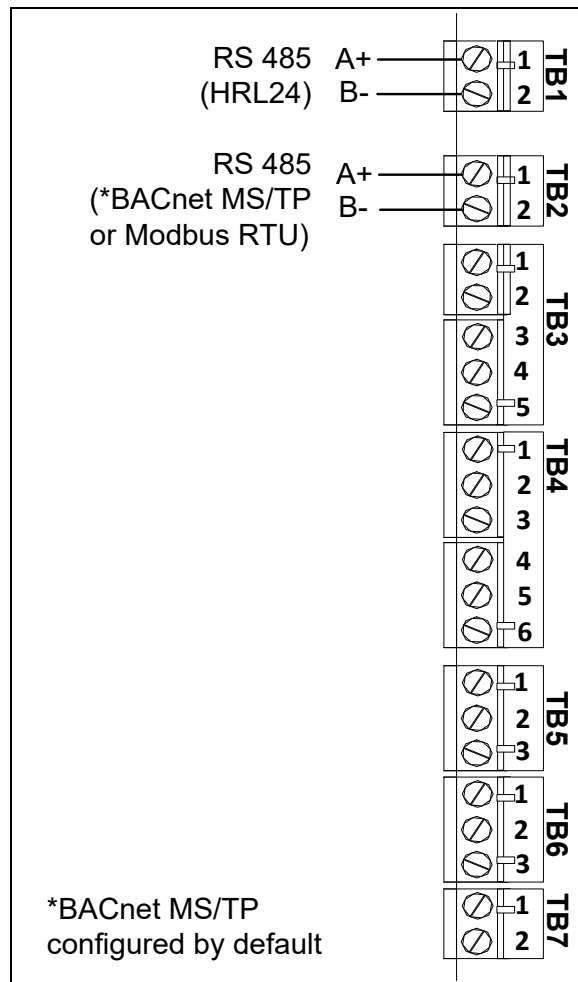

Illustration 46 - Network Communication Connections

Controls Placement (Steam Dispersed into a Duct or AHU)

A typical humidifier control system includes the following along with the humidifier:

- A wall or return duct humidistat
- A high limit duct humidistat
- An airflow switch

Placement of these devices is critical to the proper operation of the overall system.

- The return air humidistat must always be located in the return air duct, to ensure accurate sensing of the air from the humidified space.
- Alternatively, a room humidistat can be used. The room humidistat must be located on an inside wall or column. It must not be near any discharge air from supply ducts or sources of heat or cold.
- The airflow switch must be placed in a position capable of accurately opening on a loss of air flow, to prevent the humidifier from running when there is no air to absorb humidity.
- The high limit humidistat must be positioned far enough, minimum 4.6 m, downstream of the steam dispersion manifold(s) to prevent over humidification of the duct that could result in condensation.
- Any device that may be triggered by high humidity levels in close proximity to the steam dispersion manifold must also be positioned at least 4.6 m, downstream of the dispersion manifold(s).

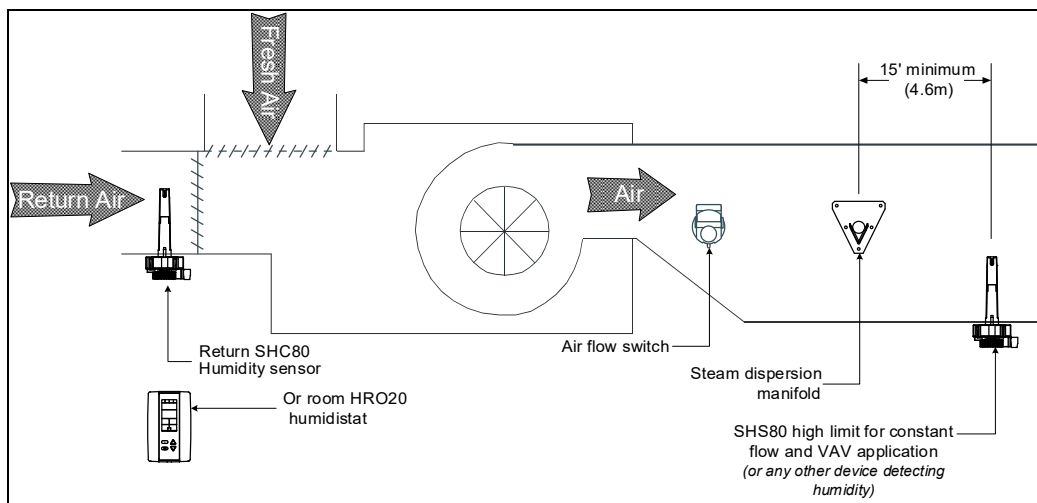

Illustration 47 - Controls Placement (Steam Dispersed into a Duct or AHU)

Controller Configuration

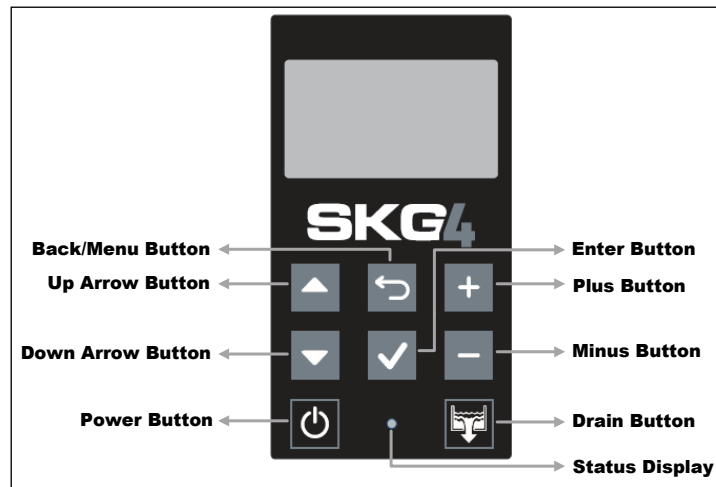













Illustration 48 - SKG4 Controller

Control Panel Features

The following are the features of the Control Panel and their description:

Table 16 - Humidifier Control Panel Description

Feature		Description
Status Display	 (Blue)	Indicates that the humidifier is turned on. The LED will begin blinking as the system is initializing.
	 (Red)	Indicates that the alarm is issuing a warning and that the system must be verified.
	 (Off)	Indicates that the humidifier is turned off.
Power Button		The power button is used to turn the humidifier on or off. Must be pressed and held for 3 seconds to perform the related action, in order to prevent accidental activation. Even when the humidifier is powered off, the controller remains operational.
Drain Button		The drain button is used to manually activate the drain cycle. Must be pressed and held for 3 seconds to perform the related action, in order to prevent accidental activation. Even when the humidifier is powered off, a drain cycle may be initiated. <i>Once the manual drain cycle is completed, the system will automatically be powered off. To turn the humidifier back on, press and hold the power button.</i>
Up and Down Arrow Buttons	 	The up arrow button is used to scroll to the next menu item or parameter. The down arrow button is used to scroll to the previous menu item or parameter.
Plus and Minus Buttons	 	The plus button is used to increase the value of the displayed parameter. The minus button is used to decrease the value of the displayed parameter.
Back/Menu Button		The back/menu button is used to go to previous menu or to access the Main Menu page from the Idle Screen.
Enter Button		The enter button is used to advance to the next sub-menu, to access the selected option or to confirm set parameter value.

Idle Screen

When the controller is in operation, the unit displays the following information on the Idle Screen:

Table 17 - Idle Screen Display Description

Setting	Default	Range (* indicates no configuration; display only)	Description/Notes
HumDemand:	Current value	* (min: 0.00%, max: 100.00%)	Displays the current humidity demand value.
ControlState:	Current value	* (Off, Normal, LowLimit, HighLimit, NoAirFlow, Interlock)	Displays the current state of the safety control circuit and whether the circuit has been disconnected due to a safety switch.
PowerOutput:	Current value	* (min: 0.00%, max: 100.00%)	Displays the measured power output of the system as a percentage of the total power.

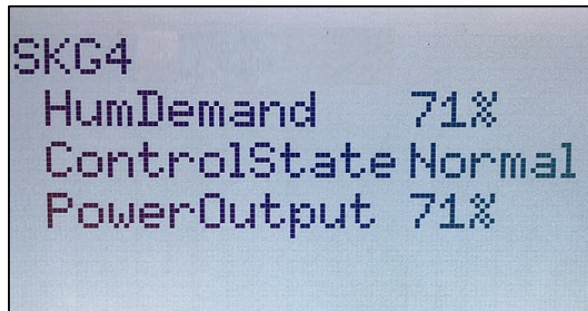

Illustration 49 - Idle Screen Display

Menu Access

- From the Idle Screen, the Main Menu can be accessed by pressing the Back/Menu button ↵, enabling access to the General menu.
- To view other menu options and perform configurations to the system, press Enter ✓ while on the Idle Screen to advance to the Login Screen, where a valid password must be entered.
- Four different passwords can be used, each granting access to an additional menu option depending on the access level assigned to the provided password.
- If a password of higher access is provided, all menu options accessible with the use of a lower level password will also be unlocked.

Table 18 - Access Levels

Access Level	Password	Menu Unlocked	Description/Notes
1	None	General	Grants access to General menu.
2	2222	User	Grants access to General and User menus.
3	3322	Service	Grants access to General, User and Service menus.
4	4433	Installation	Grants access to General, User, Service and Installation menus.
5	5544	Integration	Grants access to General, User, Service, Installation and Integration menus.



Note: To modify or retrieve lost passwords, please contact factory.



- A. After accessing the Login Screen, use the + or - buttons to increase or decrease the value of the number that is highlighted.
- B. Use the ▲, ▼ buttons to scroll to the next or previous number.
- C. Press Enter ✓ to confirm the password once completed. If you enter the wrong password, the SKG4 controller displays a "Login Failed" message.
- D. The Back/Menu button ↵ may also be used to return to the Idle Screen display.



Illustration 50 - Login Screen

Menu Navigation and Configuration

- A. Use the ▲, ▼ buttons to select the desired menu category and press Enter ✓ to advance to the next sub-menu.
- B. Use the + and - buttons to increase and decrease values. Use the ▲, ▼ buttons to scroll to the next or previous parameter. Values are saved as soon as a change is made.
- C. Press the Back/Menu button ↵ to go back one menu. The current menu location is displayed at the top of the screen.
- D. To exit completely, press the Back/Menu button ↵ until you return to the Idle Screen. After 5 minutes of inactivity, the controller will automatically return to the Idle Screen.

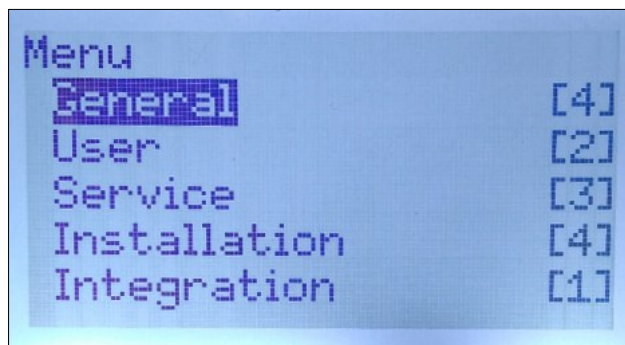

Illustration 51 - Main Menu Page



Note: Available settings and range selections may vary depending on current configuration. The tables in the following sections display all the possible selections. The Description/Notes column indicates the conditions required for the associated setting to appear.

Menu - General [Level 1 - No password required]

Press the back/menu button from the Idle Screen to access the General menu

Sub-Menu	Setting	Default	Range <i>(* indicates no configuration; display only)</i>	Description/Notes	
Status	Interlock:	Closed	* (Closed, Open)	Displays the status of the interlock. If <i>Open</i> is displayed, it indicates that the humidifier is stopped as a result of the interlock safety being open.	
	SupplyHighLimit:	Closed	* (Closed, Open)	Displays the status of the high limit contact. If <i>Open</i> is displayed, it indicates that the humidity level has exceeded the setpoint on the high limit humidistat.	
	AirFlow	Closed	* (Closed, Open)	Displays the status of the airflow switch. If <i>Open</i> is displayed, it indicates that the airflow is not detected by the air pressure switch.	
	OccupancyState:	<i>Current value</i>	* (Occupied, Unoccupied, Vacant, Off)	Displays the current occupancy state.	
	HumDemand:	<i>Current Value</i>	* (min: 0%, max: 100%)	Displays the current humidity demand value.	
	ControlState:	<i>Current Value</i>	* (Off, Normal, LowLimit, HighLimit, Airflow, Interlock)	Displays the current state of the safety control circuit and whether the circuit has been disconnected due to a safety switch.	
	PowerOutput:	<i>Current value</i>	* (min: 0%, max: 100%)	Displays the measured power output of the system as a percentage of the total power.	
	Module1 to 4 [4]				
		BoilerDemand:	<i>Current value</i>	* (min: 0.00%, max: 100.00%)	Displays the measured humidity demand of the humidifier module.
		ServiceDue:	No	* (No, Yes)	Displays whether the humidifier module is due for servicing.
	Module1State to 4:	<i>Current value</i>	* (Off, Idle, LineRinse, TankRinse, Filling, Draining, Heating, Boiling, Alarm, PurgeAir)	Displays the current state of operation of the humidifier module.	
	WtrProbeFail:	None	* (None, Capacitive, Resistive, Both)	Displays which one of the water level sensor's probes is currently not functioning properly.	
Control	RoomDemand:	<i>Current value</i>	* (min: 0%, max: 100%)	Displays the room humidity demand value. (Only appears if ControlProfile is set to an internal control mode.)	
	SupplyHLDemand:	<i>Current value</i>	* (min: 0%, max: 100%)	Displays the supply high limit humidity demand value. (Only appears if ModHLProfile is set to an internal control mode.)	
Physical IO	WtrLeakDet:	Ok	* (Ok, Leak)	Displays whether a water leak has been detected. If <i>Leak</i> is displayed, it indicates that there is a leak within the water line.	
	SupplyHLRH:	<i>Current value</i>	* (min: 0%, max: 100%)	Displays the supply high limit humidity reading value. (Only appears if ModHLProfile is set to InternAnalog.)	
	RoomRH:	<i>Current value</i>	* (min: 0%, max: 100%)	Displays the room humidity reading value. (Only appears if ControlProfile is set to InternHumAnalog.)	
	ControlInput:	<i>Current value</i>	* (min: 0%, max: 100%)	Displays the current control input reading.	
	BinExtDemand:	0%	* (0%, 100%)	Displays whether there is currently a humidity demand, when an On/Off humidifier is used. (Only appears when using an On/Off humidifier.)	
	Interlock:	Closed	* (Closed, Open)	Displays the status of the interlock. If <i>Open</i> is displayed, it indicates that the humidifier is stopped as a result of the interlock safety being open.	

Sub-Menu	Setting	Default	Range (* indicates no configuration; display only)	Description/Notes	
Physical IO	SupplyHighLimit:	Closed	* (Closed, Open)	Displays the status of the high limit contact. If <i>Open</i> is displayed, it indicates that the humidity level has exceeded the setpoint on the high limit humidistat.	
	AirFlow:	Closed	* (Closed, Open)	Displays the status of the airflow switch. If <i>Open</i> is displayed, it indicates that the airflow is not detected by the air pressure switch.	
	ServiceWarnRelay:	<i>Current value</i>	* (Off, On)	Displays the status of the service warning relay.	
	AlarmWarnRelay:	<i>Current value</i>	* (Off, On)	Displays the status of the alarm warning relay.	
	PowerOutFdbck:	<i>Current value</i>	* (min: 0.00%, max: 100.00%)	Displays the feedback value of power output analog output.	
	WtrLvl1:	<i>Current value</i>	* (min: 0%, max: 120%)	Displays the percentage of water remaining in the evaporation chamber for the first humidifier module.	
	WtrLvl2:	<i>Current value</i>	* (min: 0%, max: 120%)	Displays the percentage of water remaining in the evaporation chamber for the second humidifier module. (Only appears when there is a second humidifier module.)	
	WtrLvl3:	<i>Current value</i>	* (min: 0%, max: 120%)	Displays the percentage of water remaining in the evaporation chamber for the third humidifier module. (Only appears when there is a third humidifier module.)	
	WtrLvl4:	<i>Current value</i>	* (min: 0%, max: 120%)	Displays the percentage of water remaining in the evaporation chamber for the fourth humidifier module. (Only appears when there is a fourth humidifier module.)	
	Module1 to 4 [17]				
		ChimneyTemp1 to 4:	<i>Current value</i>	* (min: 0.0°C, max: 260.0°C) Units: C, F	Displays the flue gas temperature value.
		WtrTemp1 to 4:	<i>Current value</i>	* (min: 0.00°C, max: 125.00°C) Units: C, F	Displays the temperature of water in the evaporation chamber.
		WtrFreq:	<i>Current value</i>	* (min: 0 Hz, max: 30000 Hz)	Displays the measured input frequency of the water level sensor.
		AmbientTemp1 to 4:	<i>Current value</i>	* (min: -40.00°C, max: 100.00°C) Units: C, F	Displays the temperature value inside of the weather proof enclosure. (Only appears for units with the weather proof enclosure.)
		FanFdbck:	<i>Current value</i>	* (min: 0Hz, max: 2000Hz)	Displays the feedback value from the burner fan.
		FanPWM:	<i>Current value</i>	* (0.0%, 100.0%)	Displays the strength of the PWM control signal from the burner fan.
		BurnerAirInlet:	Normal	* (Normal, Blocked)	Displays the status of the burner inlet air pressure switch. If <i>Blocked</i> is displayed, it indicates that the air pressure switch is open due to the burner inlet being blocked.
		WtrLvlLow:	<i>Current value</i>	* (Inactive, Active)	Displays the status of the resistive low water level sensor.
		WtrLvlHigh:	<i>Current value</i>	* (Inactive, Active)	Displays the status of the resistive high water level sensor.
		FoamSensor1 to 4:	NoFoam	* (NoFoam, Foam)	Displays whether foam has been detected within the evaporation chamber. If <i>Foam</i> is displayed, it indicates that the Anti-Foaming Energy Conservation (AFEC) system has detected foam. The humidifier will drain for a few minutes and return to normal operation.
	GasValve:	<i>Current Value</i>	* (Off, On)	Displays the status of the gas valve.	
	TankWtrValve:	<i>Current value</i>	* (Off, On)	Displays the status of the evaporation chamber water supply valve.	
	WtrLvlValve:	<i>Current value</i>	* (Off, On)	Displays the status of the water level sensor supply valve.	
	DrainCoolValve:	<i>Current value</i>	* (Off, On)	Displays the status of the internal drain cooler valve.	
	DrainPump:	<i>Current value</i>	* (Off, On)	Displays the status of the drain pump.	
	IgnitionCtrl:	<i>Current Value</i>	* (Off, On)	Displays the status of the ignition control module.	
	DrainValve:	On	* (On, Off)	Displays the status of the normally open drain valve. (Only appears for units with the weather proof enclosure.)	

Sub-Menu	Setting	Default	Range <i>(* indicates no configuration; display only)</i>	Description/Notes
System	SysStatus:	Operational	* (Operational, Operational Read-Only, Download required, Download in progress, Non-operational, Backup in progress)	Displays the current system status.
	Vendor:	Neptronic	*	Displays the name of the vendor of the product. (Always Neptronic)
	Model:	-	*	Displays the humidifier model name.
	AppVersion:	2.07	*	Displays the current application software version.
	SerialNo:	-	*	Displays the serial number of the humidifier.
	Profile:	-	*	Displays a short profile for the configured device.
	MCULoad:	<i>Current value</i>	* (min: 0%, max: 100%)	Displays the current microcontroller load.
	MemoryLoad:	<i>Current value</i>	* (min: 0%, max: 100%)	Displays the current memory load.
	Runtime:	<i>Current value</i>	* (min: 0 sec, max: 999999999 sec)	Displays the number of seconds that the system has been powered on. This value is reset every time the system is shut off.
ResetReason:	None	* (None, BOR, Pin, POR, Soft, IWDG, WWDG, LPWR, Unknown)	Displays the reason for the previous system reset: <i>None = No Reset; BOR = Brownout Reset; Pin = Pin Reset (using PCB Reset Button); POR = Power-on Reset; Soft = Software Reset; IWDG = Independent Watchdog; WWDG = Windowed Watchdog; LPWR = Low Power Reset; Unknown = Unknown Cause</i>	

Menu - User Settings [Level 2 - Requires level 2 (or higher) password in order to access]

Sub-Menu	Setting	Default	Range	Description/Notes
Command	OccupSchedule	-	00:00 Monday to Sunday Event 1 to Event 6	Create a customized occupancy schedule with up to six events per day.
Control	RoomDemandLoop [3]			Only appears if <i>ControlProfile</i> is set to an internal control mode.
	RoomRHStp:	40.0%	min: 0.0%, max: 100.0%	Define the room demand setpoint value used during <i>Occupied</i> state.
	RoomRHUnocStp:	30.0%	min: 0.0%, max: 100.0%	Define the room demand setpoint value used during <i>Unoccupied</i> state.
	RoomRHHvacStp:	20.0%	min: 0.0%, max: 100.0%	Define the room demand setpoint value used during <i>Vacant</i> state.
Control	SupplyHLLoop [1]			Only appears if <i>ModHLLProfile</i> is set to an internal control mode.
	SupplyHLStp:	80.0%	min: 0.0%, max: 100.0%	Define the supply high limit demand setpoint value.
System	UTCOffset:	-300min	min: -720min, max: 720min	Configure the value of the UTC offset.
	DaylightSavings:	No	No, Yes	Select whether to enable daylight savings or not.
	LocalDateTime:	YYYY-MM-DD 00:00:00		Configure the current date and time.
Interface	LocalDisplay [5]			
	BacklightLvl:	25%	min: 0%, max: 100%	Select the backlight level of the LCD screen.
	Contrast:	5%	min: 0%, max: 30%	Select the contrast level of the LCD screen.
	KeypadBuzzer:	Inactive	Inactive, Active	Select whether to enable or disable the key press sound.
	Language:	English	English, French, Spanish	Select the device language.
	Units:	Imperial	Metric, Imperial	Select whether to use a metric or imperial system of units for the local device.
	HRL [5]			For units connected to the HRL24 controller. Only appears if <i>ControlProfile</i> is set to HRL.

Sub-Menu	Setting	Default	Range	Description/Notes
	Temperature:	<i>Current value</i>	* (min: -40.0°C, max: 260.0°C) Units: C, F	Displays the room temperature value measured by the HRL24 controller.
	TempBias:	0.00Δ°C	min: -10.00Δ°C, max: 10.00Δ°C Units: Δ°C, Δ°F	Set the bias value for the temperature measured by the HRL24 controller.
	Humidity:	<i>Current value</i>	* (min: 0.0%, 100.0%)	Displays the room humidity value measured by the HRL24 controller.
	HumidityBias:	0.0%RH	min: -10.0%RH, max: 10.0%RH Units: %RH	Set the bias value for the humidity measured by the HRL24 controller.
	LockSetpnt:	Unlock	(Unlock, lock)	Displays whether the setpoint obtained from the HRL24 controller can be modified or not.

Menu - Service [Level 3 - Requires level 3 (or higher) password in order to access]

Sub-Menu	Setting	Default	Range (* indicates no configuration; display only)	Description/Notes
Status	Module 1 to 4 [7]			
	RunTime:	0.00hr	*	Displays the total runtime of the humidifier module.
	ServOnTime:	0.00hr	*	Displays the operating time of the humidifier module, since the last servicing.
	ServRunTime:	0.00hr	*	Displays the runtime of the humidifier module, since the last servicing.
	OnTime:	0.00hr	*	Displays the total operating time of the humidifier module.
	IgnitionCount:	0	*	Displays the number of times the module humidifier module has made a complete ignition cycle.
	ManCalibTime:	0.00hr	*	Displays the amount of time that has been elapsed since the last manual calibration of the water level sensor. (Only appears if WtrAutoCalib1 to 4 is set to Off).
	ServiceDue:	No	* (No, Yes)	Displays whether the humidifier module is due for servicing.
Command	DrainSchedule:	-	00:00 Monday to Sunday Event 1 to Event 6	Create a customized draining schedule with up to six events per day.
	SysRequest:	None	None, Reset Alarms, Drain, Reset Counters, Filling, WaterCalib, PurgeAir	Perform one of the following actions for the whole system: reset warning alarms, initiate a drain cycle, reset service counters, fill the evaporation chamber, calibrate the water level sensor or perform an air purge.
	Mod1Request	None	None, Reset Alarms, Drain, Reset Counters, Filling, WaterCalib, PurgeAir	Perform one of the following actions for the first humidifier module: reset warning alarms, initiate a drain cycle, reset service counters, fill the evaporation chamber, calibrate the water level sensor or perform an air purge.
	Mod2Request	None	None, Reset Alarms, Drain, Reset Counters, Filling, WaterCalib, PurgeAir	Perform one of the following actions for the second humidifier module: reset warning alarms, initiate a drain cycle, reset service counters, fill the evaporation chamber, calibrate the water level sensor or perform an air purge. (Only appears when there is a second humidifier module.)
	Mod3Request	None	None, Reset Alarms, Drain, Reset Counters, Filling, WaterCalib, PurgeAir	Perform one of the following actions for the third humidifier module: reset warning alarms, initiate a drain cycle, reset service counters, fill the evaporation chamber, calibrate the water level sensor or perform an air purge. (Only appears when there is a third humidifier module.)
	Mod4Request	None	None, Reset Alarms, Drain, Reset Counters, Filling, WaterCalib, PurgeAir	Perform one of the following actions for the fourth humidifier module: reset warning alarms, initiate a drain cycle, reset service counters, fill the evaporation chamber, calibrate the water level sensor or perform an air purge. (Only appears when there is a fourth humidifier module.)

Menu - Installation [Level 4 - Requires level 4 (or higher) password in order to access]

Sub-Menu	Setting	Default	Range (* indicates no configuration; display only)	Description/Notes
Import User Config				Import all the humidifier configuration values onto the SD card or USB device. A SD card or USB device must be inserted in order to import the values.
Export User Config				Export all the humidifier configuration values onto the SD card or USB device. A SD card or USB device must be inserted in order to export the values.
Command	Module1 to 4:	On	Off, On	Select which modules to power off, in order to leave only the module being adjusted as active. (Only appears if <i>Balancing</i> is set to <i>On</i>.)
	Balancing:	Off	Off, On	Select whether to switch to balancing mode in order to perform a combustion adjustment. If set to <i>On</i> , the <i>Power1 to 4</i> and <i>BalanceDem</i> settings will appear.
	BalanceDem:	NotUsed	NotUsed, Off, Min, Max	Select the demand level to use when performing a combustion adjustment: <i>NotUsed</i> = use the humidifier demand value, <i>Off</i> = 0% demand, <i>Min</i> = 10% demand, <i>Max</i> = 100% demand. (Only appears if <i>Balancing</i> is set to <i>On</i>.)
Quick Config	BlowdownRate:	0%	min: 0%, max: 100%	Define the rate of boiler blowdown or water dilution, in order to minimize water impurities.
	DrainInterval:	6hr	min: 0hr, max: 24hr	Set the frequency of the drain cycle. In general, a more frequent drain cycle is required as the water hardness level rises. The drain cycle setting does not affect the AFEC system.
	IdleTime:	24hr	min: 0hr, max: 72hr	Set the amount of time the humidifier can remain in standby mode until an automatic drain cycle is performed.
	ServInterval:	1000hr	min: 1000hr, max: 3000hr	Set the time of operation before the humidifier calls for servicing.
	DrainVolume	100%	min: 25%, max: 100%	Define the volume of water that is drained from the chamber, relative to the total capacity of the chamber.
	ServOperation:	Allowed	Allowed, NotAllowed	Select whether to enable the unit to continue producing steam, even when it is due for servicing. When set to <i>Allowed</i> , the unit will continue operating even when a service alarm is active.
	FillMode:	Pulsed	OneShot, Pulsed	Select the water filling method for the fill valve: When set to <i>OneShot</i> , water will continuously flow. When set to <i>Pulsed</i> , water will flow in short bursts.
Control	ControlProfile:	ExternAnalog	ExternAnalog, ExternNetwork, InternHumAnalog, InternHumNetwork, HRL, Custom	Select a preconfigured control mode profile for the modulating humidity demand. Select the <i>Custom</i> option to configure individual settings. (Network option only applicable for BACnet/Modbus models.)
	ModHLLProfile:	Disabled	Disabled, ExternAnalog, ExternNetwork, InternAnalog, InternNetwork, Custom	Select a preconfigured control mode profile for the modulating high limit demand. Select the <i>Custom</i> option to configure individual settings. (Network option only applicable for BACnet/Modbus models.)
	RoomDemandLoop [4]			Only appears if <i>ControlProfile</i> is set to an internal control mode.
	Bromopropanes:	20.0	min: 1.0, max: 200.0	Set the value of the room demand proportional gain.
	RoomIntgrlTime:	0.0sec	min: 0.0sec, max: 900.0sec	Set the value of the room demand integral time.
	RoomDrvvtvTime:	0.0sec	min: 0.0sec, max: 60.0sec	Set the value of the room demand derivative time.
	RoomPropBand:	5.0%	min: 0.0%, max: 100.0%	Set the value of the room demand proportional band.
	SupplyHLLoop [4]			Only appears if <i>ModHLLProfile</i> is set to an internal control mode.
	SupplyHLLPropGain:	10.0	min: 1.0, max: 200.0	Set the value of the supply high limit demand proportional gain.
	SupplyHLLIntgrlTime:	0.0sec	min: 0.0sec, max: 900.0sec	Set the value of the supply high limit demand integral time.
	SupplyHLLDrvvtvTime:	0.0sec	min: 0.0sec, max: 60.0sec	Set the value of the supply high limit demand derivative time.
SupplyHLLPropBand:	10.0%	min: 1.0%, max: 100.0%	Set the value of the supply high limit demand proportional band.	

Control	HumidityControl [3]			
	NtwkTimeout:	900sec	min: 1sec, max: 900sec	Define the amount of time the humidifier may attempt to connect to the BACnet or Modbus network before it stops operating due to a communication error. (Only appears if ControlProfile or ModHLProfile are set to InternHumNetwork/ InternNetwork or ExternNetwork.)
	HumLowDeadBand:	1.00%	min: 0.00%, max: 100.00%	Set the lower limit deadband value for the humidity demand.
	BinDemandSrc:	None	None, BinaryExtDemand	Select the humidity control demand source for On/Off humidifiers.
Physical IO	SupplyHLRH [7]			
	Signal:	0.000V	* (min: 0.000V, max: 15.000V)	Displays the value of the duct or supply high limit humidity analog input signal.
	SupplyHLRH:	0% RH	* (min: 0% RH, max: 100% RH)	Displays the actual value of the duct or supply high limit humidity analog input.
	Min:	0% RH	min: 0% RH, max: 100% RH	Set the minimum value of the duct or supply high limit humidity analog input.
	Max:	100% RH	min: 0.00% RH, max: 100% RH	Set the maximum value of the duct or supply high limit humidity analog input.
	Bias:	0% RH	min: -10% RH, max: 10% RH	Set the bias value for the duct or supply high limit humidity analog input.
	AlwaysShow:	On	Off, On	Select whether to always display the SupplyHLRH setting, regardless of the configuration selected in the ModHLProfile setting.
	SignalType:	0-10Vdc	0-10Vdc, 2-10Vdc, 4-20mA, 0-20mA	Select the signal type for the duct or supply high limit humidity analog input.
	RoomRH [7]			
	Signal:	0V	* (min: 0V, max: 15V)	Displays the value of the room humidity analog input signal.
	RoomRH:	0% RH	* (min: 0% RH, max: 100% RH)	Displays the actual value of the room humidity analog input.
	Min:	0% RH	min: 0% RH, max: 100% RH	Set the minimum value of the room humidity analog input.
	Max:	100% RH	min: 0% RH, max: 100% RH	Set the maximum value of the room humidity analog input.
	Bias:	0% RH	min: 0% RH, max: 100% RH	Set the bias value for the room humidity analog input.
	AlwaysShow:	On	Off, On	Select whether to always display the RoomRH setting, regardless of the configuration selected in the ControlProfile setting.
	SignalType:	0-10Vdc	0-10Vdc, 2-10Vdc, 4-20mA, 0-20mA	Select the signal type for the room humidity analog input.
	ControllInput [6]			
	Signal:	0.000V	* (min: 0.000V, max: 15.000V)	Displays the value of the control demand analog input signal.
	ControllInput:	0%	* (min: 0%, max: 100%)	Displays the actual value of the control demand analog input.
	Min:	0%	min: 0%, max: 100%	Set the minimum value of the control demand analog input.
	Max:	100%	min: 0%, max: 100%	Set the maximum value of the control demand analog input.
	Bias:	0.0%	min: -10.0%, max: 10.0%	Set the bias value for the control demand analog input.
	SignalType:	0-10Vdc	0-10Vdc, 2-10Vdc, 4-20mA, 0-20mA	Select the signal type for the control demand analog input.
	SteamOutFdbck [5]			
	Signal:	0.000V	min: 0.000V, max: 10.000V	Displays the value of the power output feedback signal.
	Bias:	0.000V	min: 0.000V, max: 10.000V	Set the bias value for the power output feedback signal.
	Min:	0.000V	min: 0.000V, max: 10.000V	Set the minimum value of the power output feedback signal.
	Max:	10.000V	min: 0.000V, max: 10.000V	Set the maximum value of the power output feedback signal.
	PowerOutFdbck:	0.00%	* (min: 0.00%, max: 100.00%)	Displays the value of the power output feedback.
	Module1WtrLvIProbe to 4 [4]			Only appears if WtrAutoCalib1 to 4 is set to Off.
	LowPosReading:	30000Hz	* (min: 0Hz, max: 30000Hz)	Displays the low position value of the water level sensor.
	HighPosReading:	30000Hz	* (min: 0Hz, max: 30000Hz)	Displays the high position value of the water level sensor.
AbsLowPosReading:	30000Hz	* (min: 0Hz, max: 30000Hz)	Displays the absolute low position value of the water level sensor.	
AbsHighPosReading:	30000Hz	* (min: 0Hz, max: 30000Hz)	Displays the absolute high position value of the water level sensor.	

Physical IO	Module1 to 4 [2]			
	WtrTemp1 to 4:	50.0°C	* (min: 0.0°C, max: 125.0°C) Units: C, F	Displays the temperature of water in the evaporation chamber.
	WtrTempOffset:	0.00Δ°C	min: -10.00Δ°C, max: 10.00Δ°C Units: Δ°C, Δ°F	Set the bias value for the water temperature sensor.
System	ResetFactory:	No	No, Yes	Select Yes in order to reset the humidifier back to its original factory configuration settings. WARNING: There is no way to recover previous configurations once the device has been reset.
Extended Config	InstallationDate:	YYYY/MM/DD		Set the device installation date.
	AlarmBuzzer:	Disabled	Normal, Disabled	Select whether to enable or disable the alarm buzzer sound whenever there is a system warning. This will not affect the Status Display LED.
	Module1 to 4 [4]			
	MaxOutput:	100%	min: 0%, max: 100%	Set the maximum steam output of the humidifier module relative to its total capacity. (The minimum value may vary based on the humidifier model.)
	PowerState:	Off	Off, On	Select whether to enable or disable the humidifier module. If set to <i>Off</i> , the module will not produce any steam.
	WtrAutoCalib1 to 4:	On	Off, On	Select whether to enable or disable the automatic calibration of the water level sensor.
	HeatMaxOut1 to 4:	100%	min: 0%, max: 100%	Set the maximum heat output of the humidifier module relative to its total capacity.
	WtrLvlReplace:	7day	min: 0day, max: 7day	Set the amount of time the humidifier may run using only the resistive water level probes, if there is an issue with the capacitive probe, before an alarm message is displayed.
	BlowdownRate:	0%	min: 0%, max: 100%	Define the rate of boiler blowdown or water dilution, in order to minimize water impurities.
	DrainInterval:	6hr	min: 0hr, max: 24hr	Set the frequency of the drain cycle. In general, a more frequent drain cycle is required as the water hardness level rises. The drain cycle setting does not affect the AFEC system.
	IdleTempStpnt:	0°C	min: 0°C, max: 90°C Units: C, F	Set the idle temperature setpoint value for the evaporation chamber when there is no demand.
	IdleTime:	24hr	min: 0hr, max: 72hr	Set the amount of time the humidifier can remain in standby mode until an automatic drain cycle is performed.
	ServInterval:	1000hr	min: 1000hr, max: 3000hr	Set the time of operation before the humidifier calls for servicing.
	IdleRinseInterval:	3day	min: 1day, max: 7day	Set the amount of time the humidifier stays in "Idle" or "Off" mode, before the evaporation chamber undergoes an automatic rinse cycle.
	DrainVolume:	100%	min: 25%, max: 100%	Define the volume of water that is drained from the chamber, relative to the total capacity of the chamber.
	LineRinse:	On	Off, On	Select whether to perform an automatic pipe line rinse cycle upon each start-up of the humidifier.
	ServOperation:	Allowed	Allowed, NotAllowed	Select whether to enable the unit to continue producing steam, even when it is due for servicing. When set to <i>Allowed</i> , the unit will continue operating even when a service alarm is active.
	FillMode:	Pulsed	OneShot, Pulsed	Select the water filling method for the fill valve: When set to <i>OneShot</i> , water will continuously flow. When set to <i>Pulsed</i> , water will flow in short bursts.
	IdleRinseOff:	Off	Off, On	Select whether to enable automatic rinse cycles while the humidifier is turned off and remains inactive. To select the amount of time the humidifier remains inactive before a rinse cycle is performed, configure the value of the <i>IdleRinseInterval</i> setting.
	IdleRinseOn:	Off	Off, On	Select whether to enable automatic rinse cycles while the humidifier is turned on and remains in "Idle" or stand-by mode. To select the amount of time the humidifier remains inactive before a rinse cycle is performed, configure the value of the <i>IdleRinseInterval</i> setting.

Extended Config	SystMode:	Sequential	Parallel, Sequential, Hybrid	<p>Select under which system operation mode the different modules will operate:</p> <p>Parallel: All modules are activated at the same time and they are deactivated only if the demand is low.</p> <p>Sequential: A new module is activated only when the other modules operate at 100% of their capacity and they are deactivated as soon as they are no longer needed.</p> <p>Hybrid: A new module is activated only when the other modules operate at 100% of their capacity and they are deactivated only if the demand is low.</p> <p>(Only applicable for units having multiple modules.)</p>
	StartupRinse:	Off	Off, On	Select whether to perform an automatic tank rinse cycle upon each start-up of the humidifier.

Menu - Integration [Level 5 - Requires level 5 password in order to access]

Sub-Menu	Setting	Default	Range (* indicates no configuration; display only)	Description/Notes
Network	NtwrkOption:	BACnet	BACnet, Modbus	Select whether to connect to a BACnet MS/TP or Modbus RTU communication interface on terminal TB2 of the humidifier PCB.
	Device [4]			
	DeviceName:	-		Establish a name for the device.
	Location:	-		Establish a designated location for the unit.
	Description:	-		Establish a brief description for the unit.
	DeviceInstance:	0153001 (0x000255a9)		Define the device instance value.
	HTTPServer [1]			
	HttpServerUnits:	Metric	Metric, Imperial	Select whether to use a metric or imperial system of units for the HTTP server.
	BACnetServer [3]			
	ListMode:	Integrator	Integrator, Advanced, Factory	Select the category of BACnet objects to display.
	Units:	Metric	Metric, Imperial	Select whether to use a metric or imperial system of units for the BACnet server.
	Language:	English	English, French, Spanish	Select the language for the BACnet server.
	BACnetMSTP [10]			
	MaxMaster:	127	min: 1, max: 127	Configure MaxMaster value to increase network efficiency when there are less than 127 devices on the network. For optimal efficiency, set value to the highest MAC address in the MS/TP network.
	MaxInfoFrames:	1	min: 1, max: 100	Configure the maximum number of information messages the controller may transmit, before it must pass the token to the next controller.
	AutoBaudRate:	Yes	No, Yes	Enable or disable automatic baud rate detection.
	BaudRate:	38400	9600, 19200, 38400, 76800	Select the baud rate for data transfer.
	MAC:	001		Set the MS/TP network MAC address.
	RxValid:	0	*	Displays information on the received communication frames for troubleshooting purposes.
	RxInvalid:	0	*	
	RxLost:	0	*	
	Tx:	0	*	Displays information on the transmitted communication frames for troubleshooting purposes.
	TxLost:	0	*	
	BACnetIP [6]			
	BACnetIPPort:	47808	min: 0, max: 65535	Set the User Datagram Protocol (UDP) port number. BACnet port number is set by default.
	RxValid:	0	*	Displays information on the received communication frames for troubleshooting purposes.
	RxInvalid:	0	*	
	RxLost:	0	*	
Tx:	0	*	Displays information on the transmitted communication frames for troubleshooting purposes.	
TxLost:	0	*		
ModbusServer [1]				
Units:	Metric	Metric, Imperial	Select whether to use a metric or imperial system of units for the Modbus server.	

Sub-Menu	Setting	Default	Range (* indicates no configuration; display only)	Description/Notes	
Network	ModbusRTU1In [4]			Only appears if NtwrkOption is set to Modbus.	
	MAC:	1	min: 1, max: 247	Set the Modbus MAC address.	
	Autobaud:	No	No, Yes	Enable or disable automatic baud rate detection.	
	PortConfig:	No Parity, 2 Stop Bits	No Parity, 2 Stop Bits Even Parity, 1 Stop bit Odd Parity, 1 Stop bit	Select the Modbus communication port configuration.	
	BaudRate:	19200	9600, 14400, 19200, 38400, 57600	Select the baud rate for data transfer.	
	BACnetETH [5]				For models connected to BACnet Ethernet.
	RxValid:	0	*	Displays information on the received communication frames for troubleshooting purposes.	
	RxInvalid:	0	*		
	RxLost:	0	*		
	Tx:	0	*	Displays information on the transmitted communication frames for troubleshooting purposes.	
	TxLost:	0	*		
	ModbusTCPiP0In [2]				For models connected to Modbus TCP/IP.
	KeepAliveTimeOut:	5min	min: 1min, max: 1440min	Set the amount of time the communication stays open before connection is cut out, when no signal is received from the device.	
	ListeningPort:	502	min: 0, max: 65535	Set the communication port number. Modbus TCP port number is set by default.	
	SMTP [7]				
	SSL:	Off	Off, On	If turned to <i>On</i> , a secure socket layer will be used to encrypt the communication between the device and the email server (Port value must be set to <i>587</i> and <i>Username</i> and <i>Password</i> settings must be filled out). If turned to <i>Off</i> , the default socket will be used (use Port <i>25</i> to use server without login account or Port <i>587</i> if login details for email account have been entered).	
	Port:	25	25, 587	If set to <i>25</i> , server to server email transfer is enabled (can only be used if SSL is set to <i>Off</i>). If set to <i>587</i> , client to server email transfer is enabled.	
	ServerAddr:	192.168.100.100		Configure the server IP address for the email account.	
	From:	<i>Current value</i>		Set the email address that will be sending the humidifier notification messages.	
	To:	<i>Current value</i>		Set the email address that will be receiving the humidifier notification messages.	
	Username:	<i>Current value</i>		Set the login username for the email account.	
	Password:	<i>Current value</i>		Set the login password for the email account.	
	Notify [3]				
Alarm:	Off	Off, On	If turned to <i>On</i> , then the humidifier alarm messages will be sent to the email configured in the <i>SMTP</i> sub-menu.		
Warning:	Off	Off, On	If turned to <i>On</i> , then the humidifier warning messages will be sent to the email configured in the <i>SMTP</i> sub-menu.		
AppMsg:	Off	Off, On	If turned to <i>On</i> , then the humidifier event messages will be sent to the email configured in the <i>SMTP</i> sub-menu.		
Communication	IPSettings [10]				
	DHCP:	Inactive	Inactive, Active	Select whether to enable Dynamic Host Configuration Protocol (DHCP) to automatically provide an IP address.	
	RstIPSetting:	No	No, Yes	Select whether to restart the IP module, in order to allow recent parameter modifications to be effective.	

Sub-Menu	Setting	Default	Range <i>(* indicates no configuration; display only)</i>	Description/Notes
Communication	StaticAddress:	192.168.1.100		Configure the static IP address.
	StaticSubnetMask:	255.255.255.0		Configure the static subnet mask.
	StaticDefaultGateway:	192.168.0.100		Configure the static default gateway.
	StaticDnsServer:	192.168.10.50		Configure the static DNS server.
	ActualAddress:	<i>Current value</i>	*	Displays the actual IP address.
	ActualSubnetMask:	<i>Current value</i>	*	Displays the actual subnet mask.
	ActualDefaultGateway:	<i>Current value</i>	*	Displays the actual default gateway.
	ActualDnsServer:	<i>Current value</i>	*	Displays the actual DNS server.
ETHSettings [1]				
	EthernetMacAdd:	<i>Current value</i>	*	Displays the MAC address of the Ethernet interface. (Only applicable if using an Ethernet connection.)



List of Alarms

Table 19 - List of Alarms

Display	Description	Alarm Reset
AirFlow	Indicates that the airflow sensor is open. This fault does not trigger the alarm contact (no message will be displayed) but will prevent the humidifier from running. Verify that the signal from the airflow sensor is present at the controller's input on the PCB and verify wiring.	Automatic
SupplyHighLimit	Indicates that the high limit item is open. Verify that the signal from the supply high limit sensor is present at the controller's input on the PCB and verify wiring.	Automatic
Interlock	Indicates that the interlock and the cut-out circuitry are open. This fault does not trigger the alarm contact (no message will be displayed) but will prevent the humidifier from running. Verify that the signal from the interlock sensor is present at the controller's input on the PCB and verify wiring.	Automatic
HighLimitCutout	Indicates that the high limit cutout has been activated due to a humidity reading that exceeds the high limit setpoint. Ensure that the high limit humidistat is operating correctly and that the distance between the sensor and the steam dispersion manifold is sufficient (4.6 m).	Automatic
ChimneyTemp1 to 4	Indicates that the flue gas temperature sensor is defective or incorrectly wired. Check sensor and verify wiring.	Automatic
WtrTemp1 to 4	Indicates that the evaporation chamber water temperature sensor is defective or incorrectly wired. Check sensor and verify wiring.	Automatic
AmbientTemp1 to 4	Indicates that the weatherproof enclosure temperature sensor is defective or incorrectly wired. Check sensor and verify wiring. (Only applicable for humidifiers with the weatherproof enclosure.)	Automatic
FoamSensor1 to 4	Indicates that the foam cutout sensor is defective or incorrectly wired. Check sensor and verify wiring.	Automatic
MemoryCard (Warning)	Indicates that the SD card has been detected, but it is not operating correctly or is non-functional. Verify the SD card and replace if defective.	Automatic
USB Device (Warning)	Indicates that the USB device has been detected, but it could not be read or is not operating correctly. Verify the functionality of the USB device and replace if defective.	Automatic
Foam1 to 4 (Warning)	If <i>Detected</i> is displayed, it indicates that the foam sensor has detected foam and the humidifier is now draining. Once the drain cycle has ended, the warning message will disappear.	Automatic
ManWtrCalib (Warning)	Indicates that the water level sensor must be manually calibrated. See Manual Water Level Calibration section on page 66 for details. (Only applicable if <i>WtrAutoCalib1 to 4</i> is set to <i>Off</i> .)	Automatic
WaterLevel1 to 4 (Warning)	If <i>Replace</i> is displayed, it indicates that there a problem with either the capacitive or resistive water level probes. Ensure that all the water level probes have been wired properly. If the error persists, the warning message will change into the alarm message described below.	Manual *
WaterLevel1 to 4 (Alarm)	If <i>Defect</i> is displayed, it indicates that the water level sensor is defective or not working properly. Verify its operation and replace it if necessary. If the sensor is replaced, the humidifier will need to be turned on while there is a humidity demand in order to recalibrate the water level sensor. If <i>NoCalib</i> is displayed, it indicates that the water level sensor is not calibrated or must be recalibrated. Ensure that <i>WtrAutoCalib1 to 4</i> is set to <i>On</i> for automatic calibration. If <i>WtrAutoCalib1 to 4</i> has been changed to <i>Off</i> , ensure that the water level sensor has been manually calibrated.	Manual *
FailedPump	Indicates that there was an error during draining due to a pump failure. Verify that the drain pump is operating correctly and that it is not being hindered or obstructed.	Manual *
FillTimeout	Indicates that the water level sensor has not reached the desired value within the programmed delay. Verify and remove any obstructions in the water inlet line and verify that the shut-off valve is not closed.	Manual *
BlockedPiping	Indicates that there was an error during draining due to a blockage in the pipes. Verify and remove any obstructions in the piping and ensure that the drain outlet is not clogged.	Manual *
HeatTimeout	Indicates that the water temperature in the evaporation chamber has not reached the boiling point within the programmed delay. Verify the temperature of the supply water.	Manual *
Overheat	Indicates that the evaporation chamber temperature sensor has detected a temperature reading greater than or equal to 105°C. Verify the operation of the water level sensor and ensure that the water supply piping is not obstructed.	Manual *
WaterLeak	Indicates that a water leak has been detected. Verify the water line for signs of leaks and ensure that all piping and water connections have been properly installed and secured.	Manual *
BurnerLocked	Indicates that the burner did not ignite after three consecutive attempts. Verify that the igniter and the ignition controller are working properly.	Manual *
FanDefect	Indicates that there is no feedback from the burner fan after receiving a control signal from the controller. Verify the status and connections of the burner fan and replace if defective.	Manual *
FailedComm	Indicates that there was a communication error between modules. Verify that the communication cable between the master and slave PCB boards is properly connected and is not defective.	Manual *



Display	Description	Alarm Reset
ChimTempHi	Indicates that the flue gas temperature sensor has detected an elevated flue gas temperature reading. Verify the operation of the water level sensor and flue gas temperature sensor.	Manual *
FanBlocked	Indicates that there is a problem with the burner fan. Verify the operation of the fan and ensure that there are no obstructions in the way.	Manual *
SystBkck	Indicates that one of the humidifier modules is responsible for a global alarm causing the entire system to be unable to function. Verify the operation of the affected module to determine the source of the problem.	Manual *
TankBlocked	Indicates that there was an error while filling the evaporation chamber due to a blockage in the pipes. Verify and remove any obstructions in the piping and ensure that the water inlet is not clogged.	Manual *
RefillDelay	Indicates that the evaporation chamber has not been refilled with more water within the programmed delay after it has begun evaporating, due to a blockage in the pipes. Verify and remove any obstructions in the piping and ensure that the water inlet is not clogged.	Manual *
NtwkCtrlSt	Indicates that the communication attempt to the BMS server has exceeded the delay defined by the <i>NtwkTimeout</i> setting. Verify the wiring between the humidifier and the BACnet or Modbus network and ensure proper connection. (Only applicable for humidifiers having the BACnet or Modbus option).	Manual *
HRLState	Indicates that there is a communication error when attempting to connect to the HRL24 controller. Verify the wiring between the humidifier and the HRL24 and ensure that the controller is functioning properly. (Only applicable for humidifiers connected to the HRL24 controller).	Manual *
AntiFreeze	If <i>Drain</i> is displayed, it indicates that the drain valve is open, and the unit will empty itself to avoid freezing. This ensures that the unit will produce steam normally when it will be switched ON by a demand.	Manual *
ServiceDue	Indicates that the due date for servicing the humidifier has arrived. See Service section on page 70 for details.	Manual **
Update Device (Warning)	The update file is for another device.	Redownload proper update file and launch new update
Update CRC (Warning)	The update file is corrupted.	Redownload proper update file and launch new update
Update Fail (Warning)	The update was unsuccessful.	Relaunch update
Memory Fail (Warning)	There is a problem with the existing configuration. Either the new configuration will not be saved, or some existing configurations will not be loaded.	Change PCB

* Use *Reset Alarms* function in the *Request* settings (see page 56).

** Use *Reset Counters* function in the *Request* settings (see page 56).

Manual Water Level Calibration

If the humidifier is not equipped with the pure DI humidifier option and uses ultrapure water, the water level sensor must be manually calibrated to obtain a more accurate sensor reading. To turn off the automatic calibration of the water level sensor, access the *WtrAutoCalib1 to 4* setting located in the *Module1 to 4* parameter in the *Extended Config* sub-menu of the *Installation* menu and set its value to *Off*. Once this is done, the water level sensor will need to be manually calibrated by using the following steps:

1. To view the water level sensor, remove the front access panel.
2. To begin the manual water level calibration process, access the Request settings located in the *Command* sub-menu of the *Service* menu, and set its value to *WaterCalib*.

Step 1. The water level sensor will then initiate a drain cycle. Wait until it has finished draining. The draining process can be stopped at any time by pressing and holding Enter ✓ for 3 seconds.

Step 2. Verify that no water remains in the water level sensor and press and hold Enter ✓ for 3 seconds to proceed. If the water has not been drained completely, open the manual drain valve to remove the remaining water.

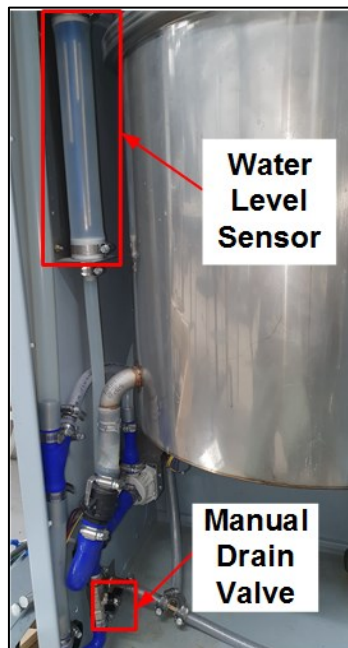

Step 3. The water level sensor will then start filling until it reaches the resistive low probe. The automatic filling process can be stopped at any time by pressing and holding Enter ✓ for 3 seconds.

Step 4. Once the *Low level* message appears on the controller, verify that the water has reached the resistive low water level probe.

- If the water has not reached the resistive low water level probe, use the + button to resume filling.
- If the water level sensor has been overfilled, open the manual drain valve to remove the additional water.
- Once the water has reached the resistive low probe, press and hold Enter ✓ for 3 seconds to proceed.

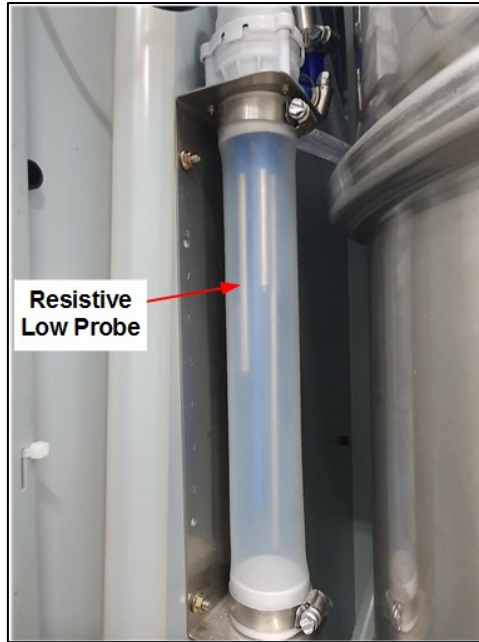

Step 5. The water level sensor will then start filling until it reaches the resistive high probe. The automatic filling process can be stopped at any time by pressing and holding Enter ✓ for 3 seconds.

Step 6. Once the *High level* message appears on the controller, verify that the water has reached the resistive high water level probe.

- If the water has not reached the resistive high water level probe, use the + button to resume filling.
- If the water level sensor has been overfilled, open the manual drain valve to remove the additional water.
- Once the water has reached the resistive high probe, press and hold Enter ✓ for 3 seconds to proceed.

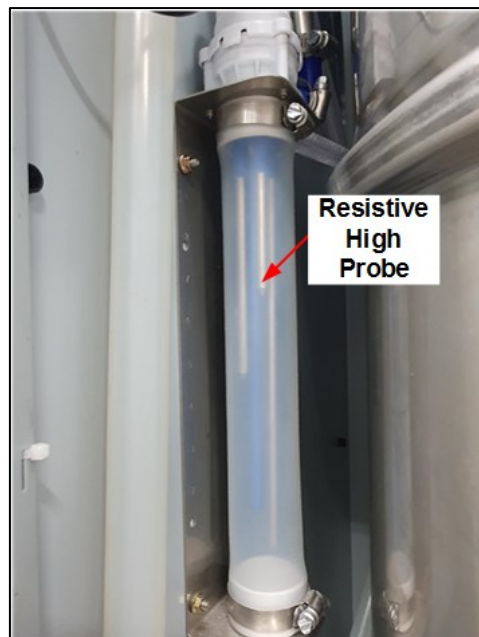

3. The manual water level calibration process is now complete.

Start-up Procedure



Initial verification and start-up must be carried out by suitably qualified personnel.

It is strictly recommended to follow this start-up procedure to avoid any anomaly resulting from inaccurate installation of the components.

Initial Verification

Clearance	1. Ensure that the humidifier cabinet is installed in a location in which the humidifier can be serviced correctly.	<input type="checkbox"/>
Electrical Supply	2. Verify that the power supply (voltage) conforms to the appliance name plate on the side of the humidifier.	<input type="checkbox"/>
Water Supply	3. Confirm that 24Vac is present between terminals TB4 1&2 on the control connection PCB. Remove the side cover to get to this PCB.	<input type="checkbox"/>
Steam	4. Ensure that water is supplied to the humidifier and that a shut-off and a non-return valve are placed outside the humidifier.	<input type="checkbox"/>
Gas Supply	5. With the water shutoff valve turned on, check that the drain connections are connected to the main drain line with sufficient diameter. Ensure that there are no apparent leaks.	<input type="checkbox"/>
Flue Gas Venting	6. Confirm that the drain piping is properly connected with a pitch of at least 6.5mm per 300mm horizontal run.	<input type="checkbox"/>
Controls	7. Verify that the steam distributors are properly installed into the ventilation duct.	<input type="checkbox"/>
Flue Gas Venting	8. Verify that the flexible steam hoses and rigid steam supply pipes are shorter than 5 m in total, are properly sloped and have condensation "S" traps wherever required.	<input type="checkbox"/>
Flue Gas Venting	9. Confirm that a proper regulator and gas test point have been installed on the gas line to the humidifier.	<input type="checkbox"/>
Flue Gas Venting	10. Confirm that gas is supplied to the humidifier and that the shut-off valve located outside the humidifier is closed. With the shut-off valve is turned on, check for leaks, gas, smell or hissing sounds.	<input type="checkbox"/>
Flue Gas Venting	11. Verify that the flue gas venting is as follows:	<input type="checkbox"/>
Flue Gas Venting	a) Ensure that a tee is installed with a drain trap for the flue gas condensate.	<input type="checkbox"/>
Flue Gas Venting	b) Check that all connections are air tight.	<input type="checkbox"/>
Flue Gas Venting	c) Ensure that the total length of the flue gas venting pipe is no longer than 30 meters.	<input type="checkbox"/>
Flue Gas Venting	d) Verify that an approved venting system has been used.	<input type="checkbox"/>
Flue Gas Venting	Note: Aluminum B vent is not acceptable.	
Controls	12. Ensure that the Airflow switch is properly installed and connected to the printed circuit board. If an Airflow switch is not used, verify that a jumper is connected between terminals TB3 1&2.	<input type="checkbox"/>
Controls	13. Ensure that the High limit duct humidistat is properly installed and connected to the printed circuit board. Verify that the setpoint is properly adjusted. If a High limit duct humidistat is not used, verify that a jumper is connected between terminals TB3 1&3.	<input type="checkbox"/>
Controls	14. Ensure that the Interlock is properly connected to the printed circuit board. If the Interlock is not used, verify that a jumper is connected between terminals TB3 1&4.	<input type="checkbox"/>
Controls	15. If a room or duct humidistat is used, verify that it is correctly installed and properly connected to the humidifier. Verify that the setpoints are properly adjusted.	<input type="checkbox"/>
Controls	16. Turn the power on using the circuit breaker.	<input type="checkbox"/>
Controls	17. Confirm the control set-up of the humidifier and verify that the setpoints are properly adjusted.	<input type="checkbox"/>



Start-Up

Start-up

1. Proceed to start-up the humidifier, as follows:
 - a) With the humidifier front access open, ensure that the manual drain valve is closed.
 - b) Turn on the humidifier by pressing and holding the Power button  for 3 seconds. Verify that the controller Status Display LED is blue.
 - c) Verify that there is a humidity demand displayed on the LCD screen of the humidifier.
 - d) Ensure that the water supply valve connected to the humidifier is turned on and that water is flowing directly to the humidifier water supply inlet. Ensure that the water shut off valve is turned off.
 - e) Verify the water level as water is filling the evaporation chamber by using the control panel to access the *WaterLevel* setting located in the *Physical IO* sub-menu of the *General* menu. Ensure that there are no water leaks along the water line.
 - f) If there is a humidity demand, the burner combustion blower(s) will start, and after approximately 90 seconds the combustion will start. From a cold water start, the humidifier will require 5 to 10 minutes to produce steam. The humidifier controller will indicate the water temperature and flue gas temperature.
 - g) During normal operation while steam is produced, the water temperature must be 100°C and the flue gas temperature must be around 120 to 200°C. The water level percentage must not indicate less than 95%.
 - h) Once the evaporation chamber has been filled, observe for water, steam and flue gas leaks during several minutes of operation.



**Combustion
Field
Adjustment**

2. Please refer to the *SKG4 Combustion Field Adjustment Instructions* enclosed in this package to perform this operation.

Safety Test

3. Check the location of the Airflow switch in the system and its operation by stopping the fan. With no air movement, the humidifier should automatically stop.

**Drain and
Reset**

4. Turn off the humidifier by pressing and holding the Power  button for 3 seconds.
5. Conduct a drain cycle by pressing and holding the Drain button  for 3 seconds. Ensure that the evaporation chamber has been emptied.
6. Once the drain cycle is complete, restart the humidifier by pressing and holding the Power  button for 3 seconds.
7. Reset the Airflow switch if needed.

End

8. The humidifier is now ready for normal operation.
-

Service



WARNING: Danger of hot water. Drain water before servicing.

The humidifier requires regular periodic service to ensure efficient and trouble-free running. Regular service involves cleaning the evaporation chamber and other humidifier components manually. Generally, frequency of cleaning can range from two months to once a year, depending on the following factors:

- Quality of water
- Frequency of automatic drain cycles
- Demand placed on the humidifier

All SKG4 humidifiers are programmed for 1000 hours of operation. This is a default factory setting.

To view the number of hours the humidifier has run and the number of service hours, use the control panel to access the *Service Menu* (see page 56 for more details).

After 1000 hours of operation have passed, the Status Display LED on the control panel will turn red, indicating that the humidifier is due for servicing. Although the humidifier will continue to operate, it is imperative that service is performed as soon as possible, in order to ensure proper functionality.

Cleaning the Humidifier

Cleaning the humidifier involves the following steps:

Stage 1 - Drain the Evaporation Chamber

Stage 2 - Shut Down the Electrical Supply

Stage 3 - Remove the Evaporation Chamber

Stage 4 - Clean the Evaporation Chamber



Stage 5 - Clean the Other Components

Stage 6 - Reinstall the Evaporation Chamber

Stage 7 - Restart the Humidifier

Stage 1 - Drain the Evaporation Chamber

Before commencing the cleaning procedure, ensure that the evaporation chamber is cool and comfortable enough to handle, as the evaporation chamber and its contents can be extremely hot and can cause burning. To allow the evaporation chamber to cool, initiate a drain cycle:

1. Press and hold the Power  button for 3 seconds to switch off the humidifier.
2. Press and hold the Drain button  for 3 seconds to initiate a drain cycle and empty the evaporation chamber.

At the end of the drain cycle, check the temperature of the evaporation chamber. To check the temperature, open the front door of the humidifier and touch the chamber with the back of your hand. If necessary, press and hold the Power  button for 3 seconds to turn on the humidifier and refill the evaporation chamber with water, then repeat the above steps until the chamber is cool enough to handle.



Stage 2 - Shut Down the Electrical Supply



CAUTION: Risk of electric shock. The electric supply of the humidifier must be shut down. Disconnect the power at the external breaker before commencing servicing.

Once the evaporation chamber is sufficiently cool, remove the power supply to the humidifier at the circuit breaker.

Stage 3 - Remove the Evaporation Chamber



The evaporation chamber may still contain some hot water. Ensure that the bottom of the evaporation chamber is cool enough to handle before removing it.

1. Turn off the gas and water supply valves located outside the humidifier.
2. With the front access door removed, disconnect the water inlet attached to the front of the evaporation chamber, by removing the safety pin and manually disconnecting the hose shank coupling. Connect and secure the water plug to the inlet in order to prevent water from leaking out from the evaporation chamber.
3. Remove the safety pin and disengage the latch, in order to disconnect the band clamp located around the evaporation chamber. Lift the band clamp up and secure it to the top flange by closing the latch.
4. Lower the evaporation chamber using the lifting mechanism. Ensure that the lifting mechanism is in contact and is supporting the chamber before lowering it.

Stage 4 - Clean the Evaporation Chamber

1. Remove the residue that has accumulated inside the chamber and pour out any remaining water that is on the bottom of the container.
2. To clean out the remaining scale from the container, use a stiff brush (synthetic filament only) and some vinegar or any weak acid suitable for cleaning stainless steel.



WARNING: The use of a wire brush or any non-recommended acid will void the warranty.

3. Do not scrape off the walls of the chamber.
4. Ensure that the water inlet aperture is not blocked.
5. Rinse out the evaporation chamber with water.





Stage 5 - Clean the Other Components

1. Ensure that the evaporation chamber gasket is in good shape and is positioned properly. Replace the gasket as necessary.
2. Clean all the components of the evaporation chamber cover, including the heat exchanger and combustion chamber. Use the same procedure as in Stage 4 to clean these components.

Stage 6 - Reinstall the Evaporation Chamber

1. Replace the evaporation chamber inside the humidifier and position it properly on the lifting mechanism. Lift the chamber back up using the lifting mechanism. Ensure that the gasket is well positioned in the cover groove.
2. Ease the evaporation chamber band clamp back into place and close the latch to lock the band clamp on the evaporation chamber. Reattach the safety pin to the band clamp.
3. Disconnect the water plug and reconnect the water inlet to the evaporation chamber.
4. Turn on the gas and water supply valves located outside the humidifier.
5. Turn the power back on using the circuit breaker.

Stage 7 - Restart the Humidifier

1. Press and hold the Power  button for 3 seconds to power on the humidifier.
2. Conduct a performance test by verifying the water level of the evaporation chamber as it is filled with water. Verify that there are no leaks.
3. Conduct a drain test by turning off the humidifier using the Power  button and performing a drain cycle using the Drain button .
4. Restart the humidifier to resume normal operation by pressing and holding the Power  button for 3 seconds.
5. To reset the service counters and clear the alarm warning after servicing:
 - a. Using the control panel, access the *Request* settings located in the *Command* sub-menu of the *Service* menu.
 - b. Select the *Reset Counters* value and press Enter  to reset the service counters.
6. Ensure that the drain cycles are set for every 6 hours of operation. This is the factory default setting and is recommended for city water.
 - To configure the drain cycle frequency, use the control panel to access the *DrainInterval* setting located in the *Quick Config* or *Extended Config* sub-menus of the *Installation* menu.

After the water boils for 6 hours in the chamber, it is laden with minerals and solutions. This affects the humidity output and the efficiency of the humidifier. Diluting the boiling water with a drain cycle will improve the performance of the humidifier.

Inspecting the Humidifier Components

Monthly Inspection

The humidifier must be inspected once a month by the operator. During the inspection, verify that:

- The flue gas passageways external to the humidifier, such as the vent connector and the chimney, are clear and free of obstructions and there is no condensate leak.
- The vent connector is in place and is in a good condition without holes or excessive corrosion.
- The air filter located in the front cover is clean.

Yearly Inspection

The humidifier must be inspected once a year by skilled and qualified technical personnel. A flue gas analyser must be used to verify the combustion quality. Verify the following during the inspection:

Combustion

- Use a flue gas analyser to verify the values of O₂, CO₂, CO, NO, and NO_x. These values must lie within the values listed in the *SKG4 Combustion Field Adjustment Instructions*.
- If any value is above the acceptable limit, the combustion needs to be readjusted. The readjustment must be done by skilled and qualified technical personnel.
- Refer to the *SKG4 Combustion Field Adjustment Instructions* for more details on the combustion adjustment procedure.

Flue Passageways

Verify that the flue passageways external to the humidifier, such as the vent connector and chimney stack, are clear and free of obstructions and that there is no condensate leak.

Vent Connector

- Ensure that the vent connector is in place and is in good condition without holes or corrosion.
- Ensure that there is no fly ash accumulation at the vent connector and inside the humidifier vent collector.
- If there is accumulation of fly ashes, the burner must be disassembled by skilled and qualified technical personnel for further inspection.

Other

Ensure that there are no obvious signs of deterioration of the humidifier.

Burner Assembly and Heat Exchanger Tube Maintenance

The heat exchanger tube and burner assembly do not require regular maintenance. However, if the heat exchange tubes contain carbon deposits, soot or other residue, the cleaning procedure described below must be followed:



Soot and carbon deposits may indicate a combustion problem. The combustion problem must be corrected by skilled and qualified technical personnel.

1. Turn off the gas valve, electrical power, and water supply valve.
2. Remove the top covers of the humidifier to gain access to the gas train.
3. Disconnect the wiring to the blower, gas valve, and igniter.
4. Disconnect the gas line from the gas valve.
5. Free the blower and gas valve by removing the nuts that hold the blower to the combustion chamber.
6. Remove the nuts that support the igniter in place. Remove the support without causing any damage to the igniter.



Maintain caution while removing the fragile igniter. It is recommended to have a spare igniter on hand.

7. Disconnect the vent from the top of the evaporation chamber.
8. Remove the combustion chamber flange, air/gas supply tube, and burner as follows:
 - a. Remove the nuts that attach the top of the evaporation chamber from the housing.
 - b. Lower and remove the top of the chamber from the front of the unit. The combustion chamber flange, air/gas supply tube, and burner can now be easily removed from the top of the evaporation chamber.
9. Clean the combustion chamber and remove any debris using a vacuum cleaner.
10. Clean the heat exchanger and remove any debris using a vacuum cleaner from the flue outlet.
11. Inspect all gaskets for damage and wear. Replace any damaged and worn out components.
12. Reinstall all components in the reverse order.

Burner Maintenance

The burner(s) does not require cleaning under normal use conditions. However, depending on the operating environment, the burner(s) may require periodic cleaning to remove accumulated materials. Failure to clean burners may result in reduced unit capacity or unacceptable flue gas CO levels.

Troubleshooting

Table 20 - Troubleshooting Guide

Problem	Possible Cause	Corrective Action
<i>Humidifier does not operate (Screen turned Off)</i>	Power is not being supplied to the humidifier.	Check the main power supply and fuses. Verify the circuit breaker.
	The low voltage fuse is open.	Check the transformer and the low voltage fuse. Verify that the low voltage circuit is complete.
	Wire harnesses inside the humidifier are not secured properly.	Check the wires harnesses and the main PC board. Verify that all connections have been made properly.
<i>Humidifier does not operate (Screen turned On, Status Display LED: Off)</i>	The humidifier is not powered on.	Verify that the Power button has been pressed and held for 3 seconds for correct activation.
<i>Humidifier does not produce steam (No demand)</i>	No analog signal detected.	Verify the setting of the control input.
	Air flow is not detected by air pressure switch.	Check the fan operation.
	High limit humidistat is open.	Check the operation of the high limit humidistat.
	Interlock contact is open.	Check the interlock contact.
<i>No water inside the evaporation chamber or Humidifier does not stop draining</i>	Control wires are not properly secured to the terminal blocks.	Verify the connections of the wires to the control terminal blocks.
	Humidifier is being filled with water but has not yet reached or does not reach the high limit of the water level sensor.	- Verify that the drain valve is open. - Check if the shutoff valve on the water supply line is open. - Verify the operation of the fill valve.
<i>Humidifier does not drain</i>	Humidifier is not being filled with water.	- Check that the fill valve strainer and the external strainer are not blocked.
	Drain valve is clogged.	Check the drain valve.
<i>Humidifier is always on Foam cycle (FoamSensor setting displays Foam)</i>	During a drain or foaming cycle, the water level sensor has sensed that the water level has not decreased.	Verify that the drain pump, the fill and drain water pipe connections and the water level sensor chamber are not obstructed.
	Excessive foaming condition inside the evaporation chamber.	- Verify the quality of the supply water. - Verify if chemical products were used to clean the evaporation chamber during maintenance. Rinse the chamber properly with water. - Check the setting of the drain cycle. Reduce the time between drain cycles.
<i>Humidifier is operating and the Status Display LED is Red (ServiceDue setting displays On)</i>	The humidifier is due for servicing.	Service the humidifier (see Service section on page 70). Use the Request settings in <i>Service</i> menu to reset counters (see page 56).
<i>Humidifier is not operating and the high temperature switch (klixon) is open</i>	The high temperature switch has sensed abnormal temperature.	Verify if the humidifier was operating below the standard water level. Replace water level sensor if necessary.
<i>Humidifier does not operate (Screen turned Off, Status Display LED: Blue)</i>	The following components can be the cause of this problem: water level sensor, PC board or LCD display.	Call factory for troubleshooting instructions.
<i>Humidifier is producing steam (Screen turned Off, Status Display LED: Blue)</i>	The display FFC cable is not connected properly.	Verify that the connections of the FFC cable are properly secured and are on the correct side.
	The LCD display is defective.	Replace the LCD display.
<i>There is an issue with the flue gas temperature sensor</i>	The PCB is not detecting the signal.	Check the electrical resistance value; it must be between 900Ω and 1100Ω. If the value is outside the range, adjust the value.
	The PCB is detecting an erroneous signal.	Replace the flue gas temperature sensor.



Problem	Possible Cause	Corrective Action
<i>Flue gas temperature is too high</i>	The water level is too low.	<ul style="list-style-type: none"> - Check if the shutoff valve on the water supply line is open. - Verify the connection between the water inlet and the evaporation chamber and ensure that it is secure. - Verify the water supply connection and ensure that it is attached properly. - Verify the operation of the fill valve.
	The water level sensor is defective.	Replace the water level sensor.
	The flue gas temperature sensor needs adjustment.	Check the reading during normal operation. If the temperature is higher than 200°C, adjust the flue gas temperature sensor.
	The flue gas temperature sensor is defective.	If after adjustment the flue gas temperature is still too high, replace the flue gas temperature sensor.
<i>Three unsuccessful burner ignitions have been made</i>	<u>An ignition lock-out (1 flash fault signal) occurred due to:</u>	
	High temperature switch	<ul style="list-style-type: none"> - Inspect the electrical wires connecting the gas control module and gas valve and ensure proper connection. - Replace the igniter.
	Defective igniter	
	<u>A weak flame (2 flash fault signal) has been detected due to:</u>	
	Incorrect positioning of the igniter	Have the igniter position verified and adjusted by skilled and qualified technical personnel.
	Damaged igniter	Replace the igniter assembly.
	<u>An internal error (3 flash fault signal) has occurred due to:</u>	
Incorrect connection	Inspect all the electrical wires connecting to the gas control module and ensure proper connection.	
Defective gas control module	Replace the gas control module.	
<i>Burner fan is not operating correctly</i>	The combustion air fan motor is not running according to the speed required for humidity demand.	<ul style="list-style-type: none"> - Inspect the venting system and remove any debris or obstructions. <u>For Natural Ventilation system:</u> <ul style="list-style-type: none"> - Replace the combustion air filter. <u>For Ducted Combustion Air option:</u> <ul style="list-style-type: none"> - Inspect the ducted combustion air system and remove any debris or obstructions.



Exploded View and Bill of Material

General

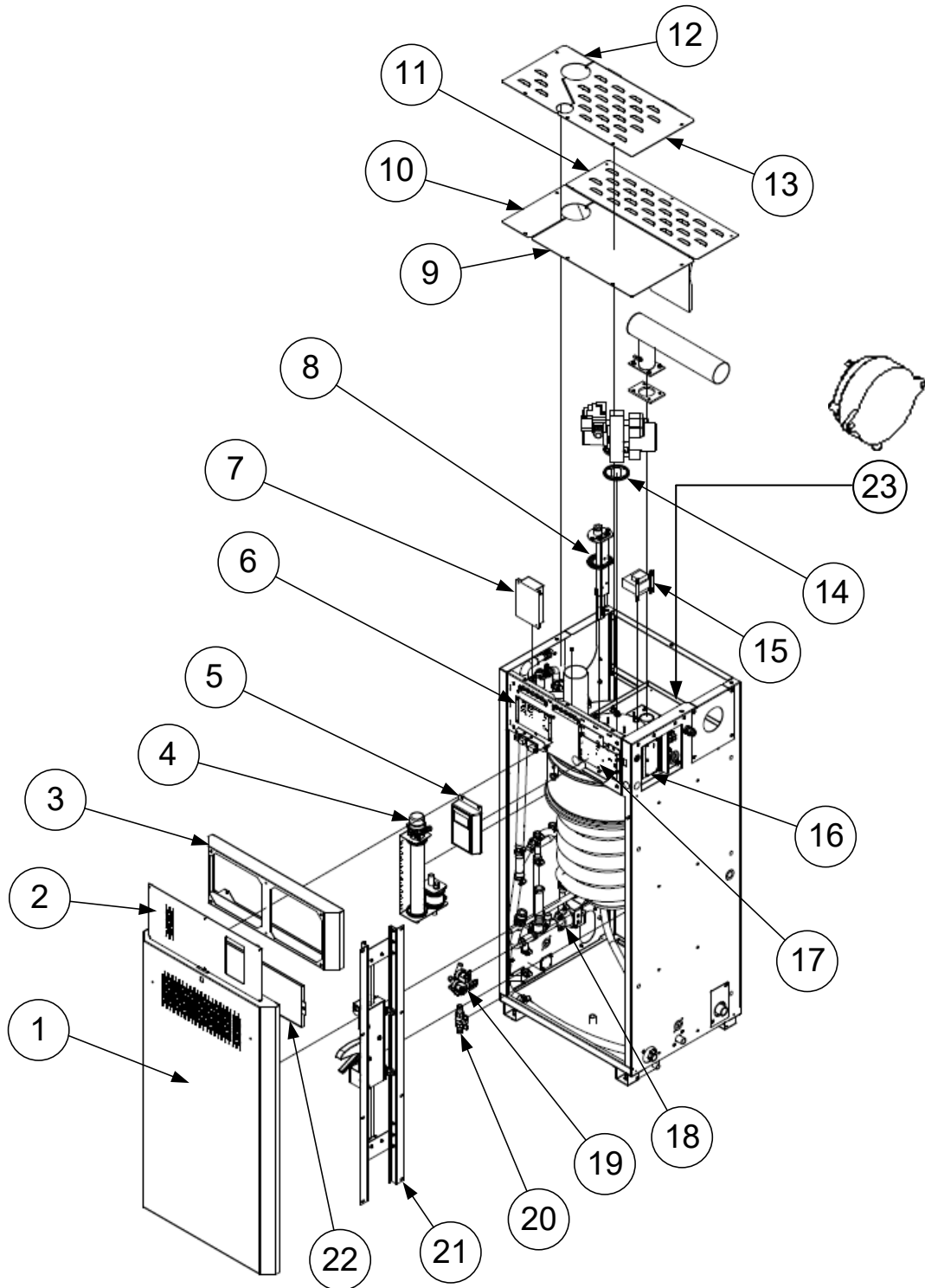

Illustration 52 - General Exploded View



Item	Description	Model	Part Number
1	Front door assembly	All models	SPG6005-1
2	Front panel	Master (1st) module	SPG6005-2
		Slave module(s)	SPG6005-5
3	Front panel box	All models	SPG6005-4
4	Water level sensor assembly	All models	SWSKG4WATLEVSENS
5	Display	All models	SWSKG4DISPLAY-AS
6	Slave PCB	All indoor models	NWSKG4SLAVESS
		All outdoor models	NWSKG4SLAVEWSS
7	Ignition control	All models	SPG2001
8	Igniter holder gasket	All models	SPG2103
9	Top front right cover	All models	SPG6005-15
10	Top front left cover	All models	SPG6005-9
11	Top back cover	All models	SPG6005-10
12	Top front left cover (direct combustion air option)	All models	SPG6005-14
13	Top front right cover (direct combustion air option)	All models	SPG6005-16
14	Combustion blower gasket	All models	SPG2104
15	Transformer	All models	SP3365
16	Control PCB	All models	NWSKG4CONNECTSS
17	Main PCB	All indoor models	SWSKG4MAINSS
		All outdoor models	NWSKG4MAINWSS
18	Drain pump	All models	SPG4101
19	Fill valve	All models	SP6009
20	Drain valve	All indoor models	SP4233-59
		All outdoor models	SP6012 (Blue Enclosure)
			SP6016 (Honeywell)
21	Lifting mechanism	All models	SWGLIFT-ASSY
22	Air filter	All models	SWG4203
23	Air pressure switch	All models	SPG2123
	Ambient temperature sensor	All outdoor models	NP242010010



Evaporation Chamber Assembly

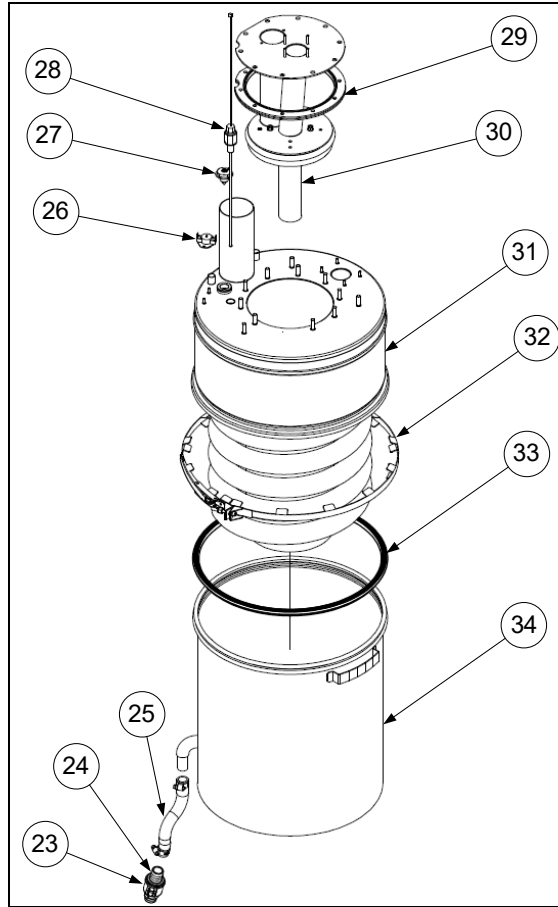

Illustration 53 - Evaporation Chamber Assembly Exploded View

Item	Description	Model	Part Number
23	Quick release drain connector (female)	All models	SP4233-11
24	Quick release drain connector (male)	All models	SP4233-12
25	Silicone hose	All models	SP1023B
26	High temperature limit switch	All models	SP3036
27	Foam sensor (AFEC)	All models	SWGAFECPROBE-ASS
28	Water temperature sensor	All models	SW G4WATTEMP-ASSY
29	Burner assembly gasket	All models	SPG2122
30	Burner assembly*	Module SKG100	SWSKG4BURN100
		Module SKG150/180	SWSKG4BURN150
		Module SKG200	SWSKG4BURN200
31	Heat exchanger*	Module SKG100/150	SWG4TANKCOVER175
		Module SKG180/200	SWG4TANKCOVER200
32	Band clamp	All models	SW GCLAMP-ASSY
33	Evaporation chamber gasket	All models	SWG2101
34	Evaporation chamber	All models	SWG3208



Note (*): Refer to the Multiple Module Composition section to obtain the appropriate module number for each SKG4 model.



Combustion Blower and Gas Valve Assembly

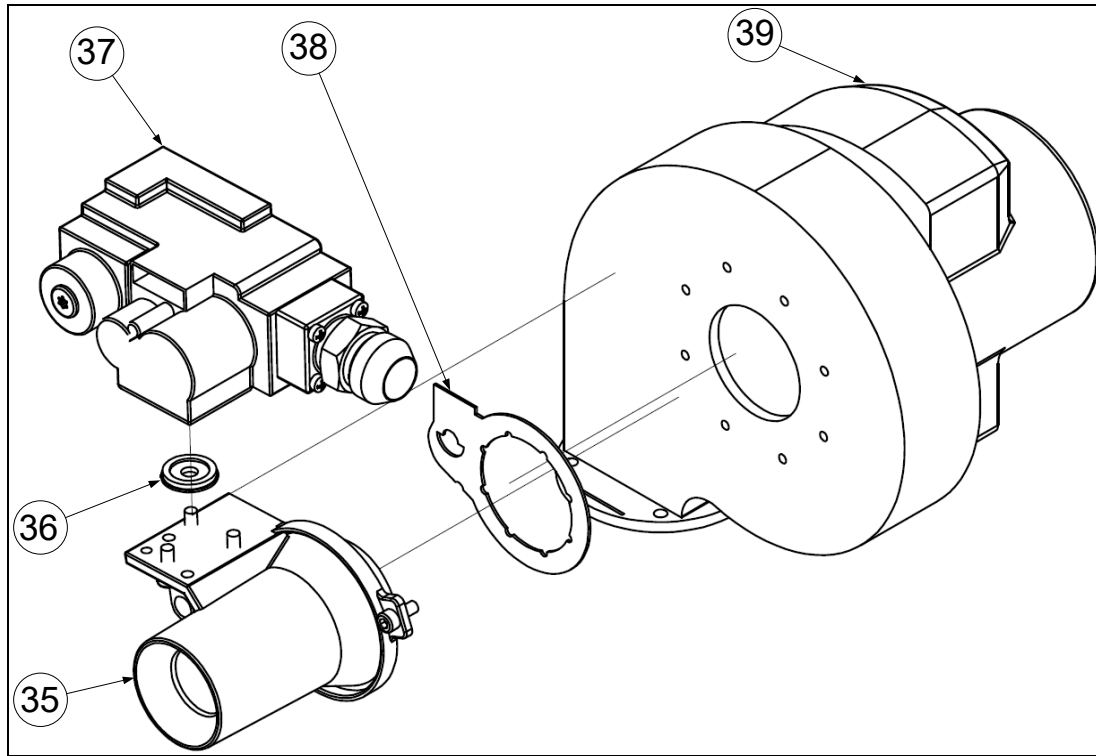

Illustration 54 - Combustion Blower and Gas Valve Assembly Exploded View

Item	Description	Model	Part Number
35	Venturi*	Module SKG100	SPG2011-03
		Module SKG150/180	SPG2011-01
		Module SKG200	SPG2011
36	Gas valve gasket	All models	SPG2008
37	Gas valve	All models	SPG2010
38	Venturi gasket	All models	SPG2116
39	Combustion blower	All models	SWG2017-230



Note (*): Refer to the Multiple Module Composition section in order to obtain the appropriate module number for each SKG4 model.

Igniter Assembly

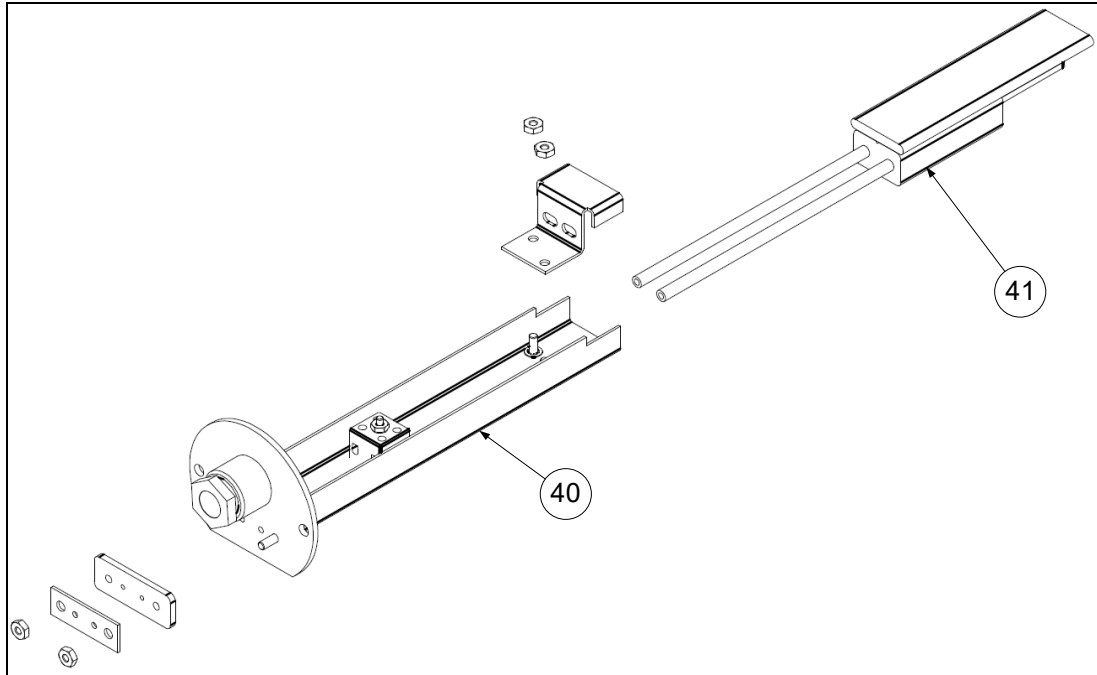

Illustration 55 - Igniter Assembly Exploded View

Item	Description	Model	Part Number
40	Igniter holder	All models	SWGIGNHOLD-H
41	Igniter	All models	SWGIGNITER-120

Internal Flue Pipe Assembly

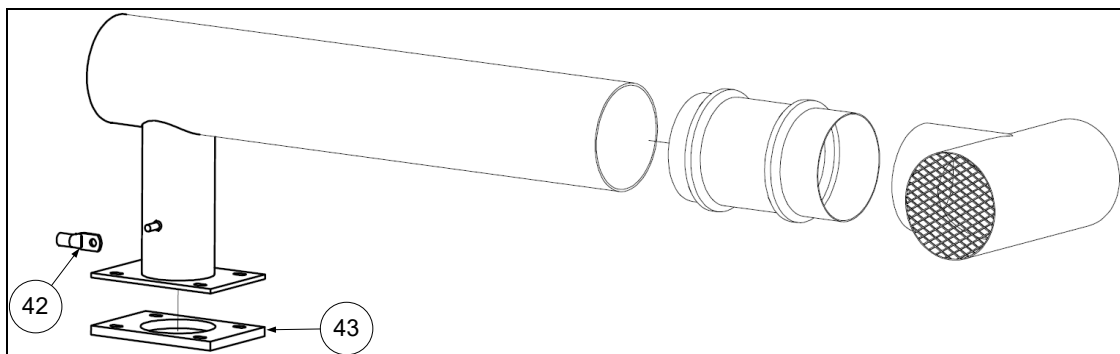

Illustration 56 - Internal Flue Pipe Assembly Exploded View

Item	Description	Model	Part Number
42	Flue temperature sensor	All models	SWG2210-ASSY
43	Flue pipe gasket	All models	SPG6008-5



Water Level Sensor Assembly (Item 4)

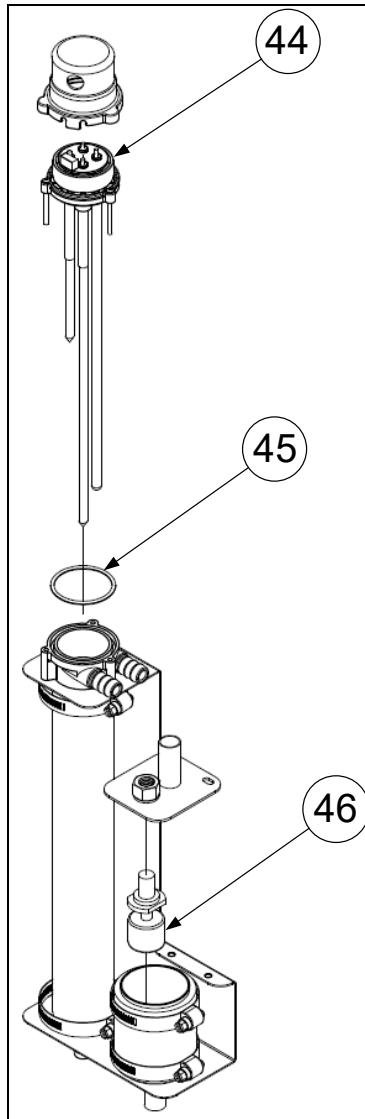
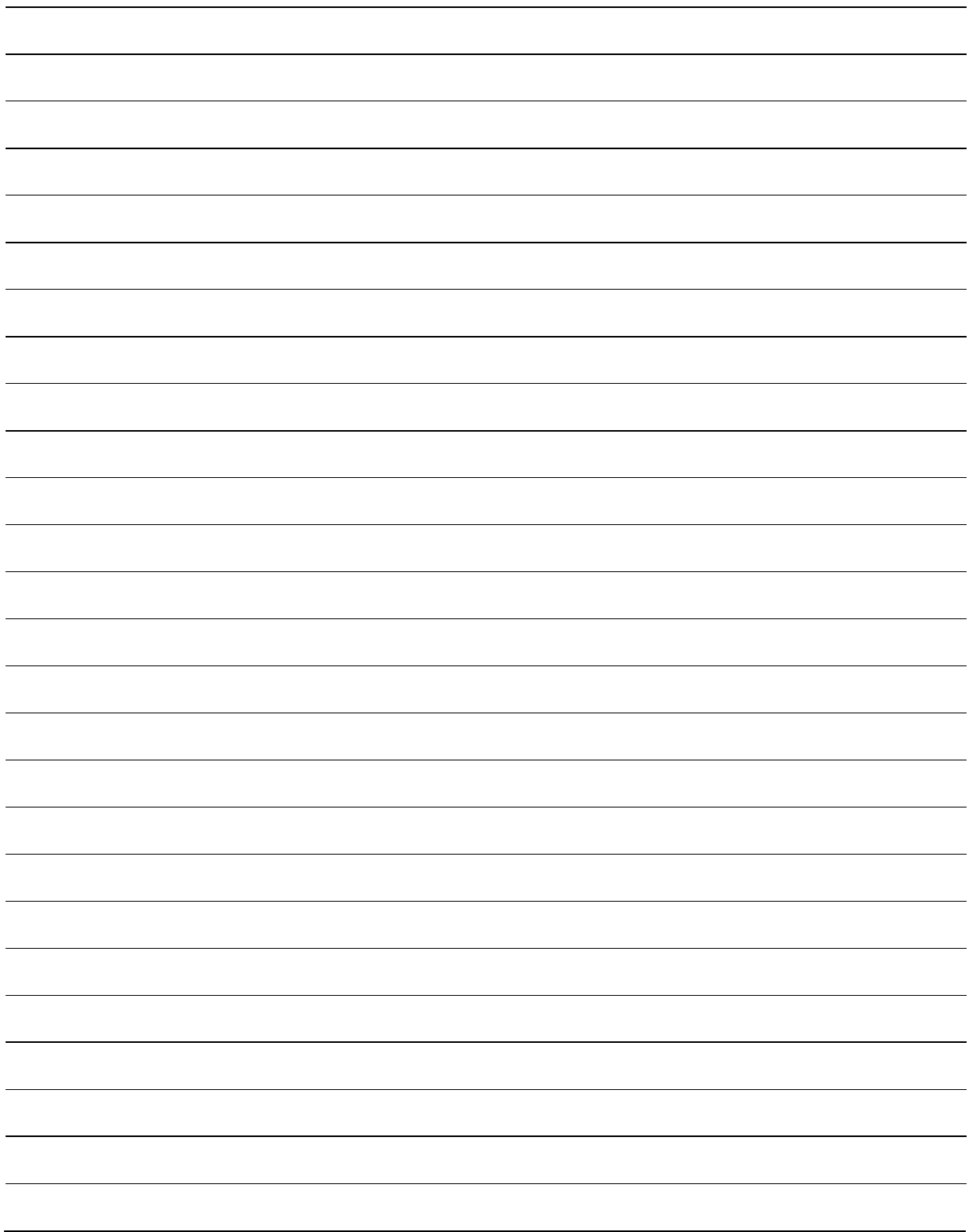

Illustration 57 - Water Level Assembly Exploded View

Item	Description	Model	Part Number
44	Water level sensor head assembly	All models	SWSK4WLTR2-HEAD
45	Water level sensor gasket	All models	SP4235-14
46	Float switch	All models	SP3600





neptronic[®]

400 Lebeau blvd, Montreal, Qc, H4N 1R6, Canada

www.neptronic.com

Toll free in North America: 1-800-361-2308

Tel.: (514) 333-1433

Fax: (514) 333-3163

Customer service fax: (514) 333-1091

Monday to Friday: 8:00am to 5:00pm (Eastern time)